

PHOENIX LIGHTING

16W LED FLOODLIGHT – ARIES



16W LED floodlight designed to replace 250W quartz halogen fixtures. Durable, compact design with various accessories available. For use on marine workboats, maintenance equipment and other demanding applications. LED technology increases efficiency, eliminates maintenance and supports green initiatives.

Construction	Marine grade cast aluminum housing
Finish	Black textured polyester powder coat
Hardware	Marine grade (316) stainless steel
Lens	Clear polycarbonate
Light Source	Cree XP-E light emitting diodes (LED) 16W Up to 789 lumens (25°), 885 lumens (40°) CRI ≥ 71 CCT 6300K 50,000 hour rated life
Power source	100-277V, 50/60Hz 72.00 inch (1829 mm) cord with pigtail NEMA 5-15 plug accessory available (120V only)
Wiring	Stranded wires
Ambient operating temperature	-30°C to +25°C
Mounting	Zinc plated, powder coated adjustable steel mounting bracket 0.531 inch (13 mm) mounting hole clearance
Weight	Fixture: 3.9 lb (1.8 kg) Package: 5.2 lb (2.4 kg)
Carton size	10.00 in x 10.00 in x 6.80 in (254 mm x 254 mm x 173 mm)
Warranty	5 years

Compliances:

ETL/cETL Certified to:

- UL 1598 Suitable for Wet Locations
- UL 1598A Marine Outside Type (Saltwater)
- CSA C22.2 No. 250.0-08

CE

ABS

IP67 rated (fixture)

LM79 and LM80 reports available

Dimensions:

Width: 6.81" (173mm)

Depth: 3.41" (87mm)

Height: 7.65" (194mm)

Options and Accessories:

25 25 degree optic

40 40 degree optic

120-277 120-277V

MBA Magnet Base Assembly

PLG-515 NEMA 5-15 plug (120V only)

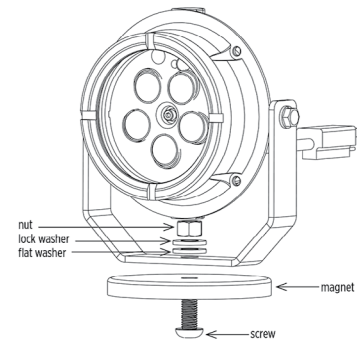
Magnet Base Assembly
MBA**MBA notes:**

- Includes magnet, screw, nut, lock washer and flat washer
- Not a suitable replacement for permanent installation
- Do not use MBA in hazardous environments
- Holding strength will vary based on application
- Holding strength for fixture and magnetic base must be deemed suitable by user