

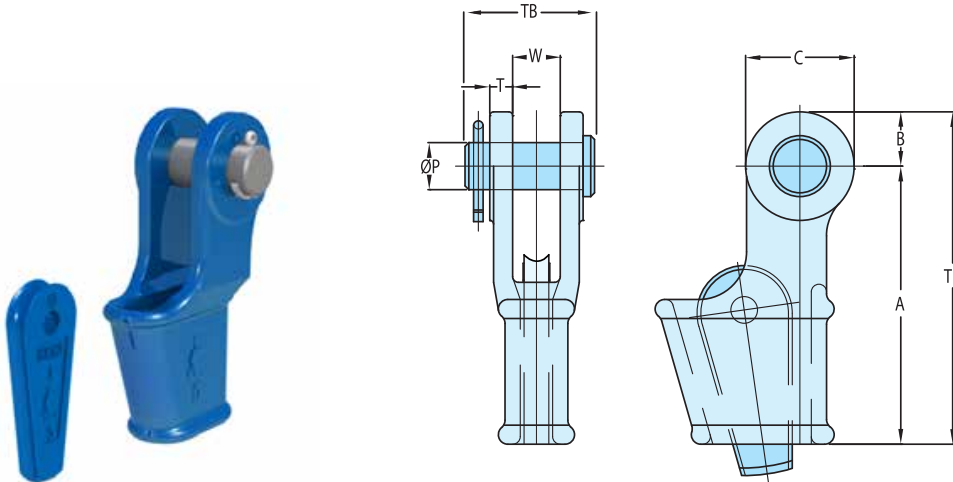

SOCKETS

OPEN WEDGE SOCKETS WITH PIN QUENCHED AND TEMPERED CAST STEEL



MODEL NR.	MBL (USTONS)	FOR WIRE Ø		DIMENSIONS (INCH)								WEIGHT (LBS)
		MM	INCH	A	B	C	Ø P	T	TL	TB	W	
OWS 0.25 P	9	7-8	5/16	4 5/16	3/4	1 7/16	5/8	3/8	5 1/16	2	11/16	2
OWS 0.5 P	13	9-10	3/8	5 11/16	7/8	1 13/16	13/16	7/16	6 1/2	2 1/2	13/16	4
OWS 1 P	22	11-13	1/2	5 3/4	1 1/8	2 1/4	1	1/2	6 7/8	2 5/8	1	5
OWS 2 P	28	14-16	5/8	6 15/16	1 3/8	2 3/4	1 3/16	9/16	8 5/16	3 3/8	1 1/4	9
OWS 3 P	44	18-19	3/4	8 2/8	1 9/16	3 1/8	1 3/8	5/8	9 13/16	3 3/4	1 1/2	15
OWS 4 P	61	20-22	7/8	9 6/16	1 7/8	3 3/4	1 5/8	3/4	11 4/16	4 5/16	1 3/4	22
OWS 5 P	83	24-26	1	10 13/16	2 3/16	4 5/16	2	7/8	13	5 1/16	2	33
OWS 6 P	99	27-29	1 1/8	12 3/16	2 9/16	5 1/8	2 1/4	1	14 3/4	5 9/16	2 1/4	46
OWS 7 P	121	30-32	1 1/4	13 3/4	2 7/8	5 3/4	2 1/2	1 1/8	16 5/8	6 1/8	2 1/2	68
OWS 8 P	138	34-36	1 3/8	15 3/4	2 15/16	5 13/16	2 1/2	1 1/8	18 11/16	6 5/16	2 3/4	82
OWS 9 P	165	37-39	1 1/2	17 11/16	3 1/8	5 9/16	2 3/4	1 3/16	20 7/8	6 15/16	3 1/16	112
OWS 10 P	187	40-42	1 5/8	19 11/16	3 7/16	6 5/16	3	1 5/16	23 1/8	7 3/8	3	141
OWS 11 P	248	43-48	1 3/4 - 1 7/8	21 5/8	3 15/16	7 5/16	3 1/2	1 9/16	25 9/16	8 7/16	3 1/2	212
OWS 12 P	309	49-52	2	25 3/16	4 1/8	8 1/16	3 3/4	1 13/16	29 5/16	9 5/8	4	287
OWS 13 P	397	54-58	2 1/4	26	4 15/16	9 13/16	4 1/4	2 1/8	30 7/8	10 13/16	4 1/2	397
OWS 14 P	468	60-68	2 1/2	32 7/8	5 5/16	10 5/8	4 3/4	2 3/8	38 3/16	11 13/16	5	606
OWS 15 P	507	72-76	3	39 3/8	5 7/8	11 13/16	5 1/4	3	45 1/4	14	5 3/4	970
OWS 16 P	689	81-86	3 1/4 - 3 3/8	43 5/16	5 14/16	11 13/16	5 1/2	3 1/8	49 3/16	14 12/16	6 1/4	1124

MBL = Minimum Breaking Load

The standard finish of our sockets is blue. Hot dipped galvanized is also available. Socket range OWS 0.25 until OWS 0.5 is delivered with galvanized finish, other finishes are available upon request. All sockets are provided with an EN 10204-2.1 declaration of conformity, EN 10204-3.1 material certificate and can be provided with a 2006/42/EC declaration where applicable. Meets performance requirements of API 2C.

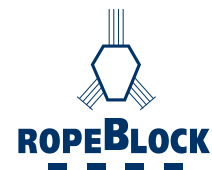

P. O. Box 596 (90748) • 910 Mahar Ave., Wilmington, CA 90744

(800) 322-3131 • (310) 522-9698 • Fax: (310) 522-1043

E-Mail: sales@watermansupply.com

www.watermansupply.com

TradeNet ID 61935