

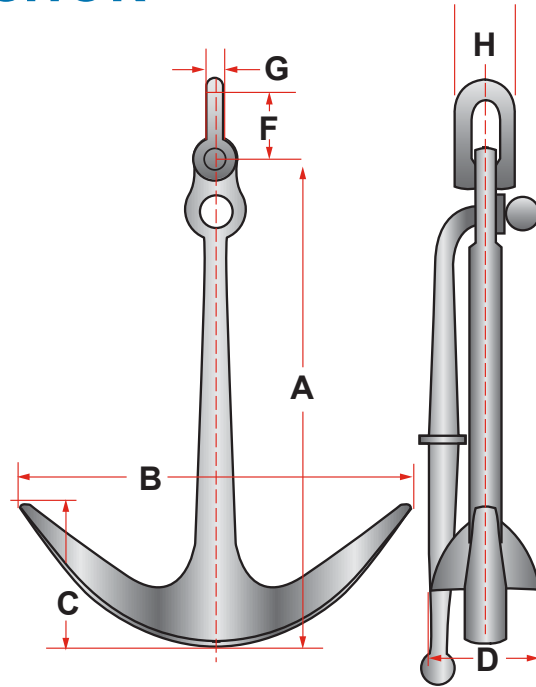

ANCHORS

OLD STYLE (KEDGE) ANCHOR

ANCHOR WT	WEIGHT N-STOCK	A	B	C	D	F	H	G	PROOF TEST
100	81	36	27	9	6	5	5	1	6850
150	119	41	31	11	8	5	5	1	7686
200	156	45	34	12	8	5	5	1	8500
250	199	49	38	13	9	7	6	1	9334
300	236	51	40	14	10	7	6	1	10090
350	274	54	42	15	10	7	6	1	10834
400	316	56	43	15	11	7	6	1	11560
450	354	58	45	16	11	7	6	1	12305
500	391	60	56	17	11	7	6	1	13030
550	429	63	49	17	12	7	6	1	13767
600	466	64	50	17	12	7	6	1	14500
650	504	66	52	18	13	7	6	1	15192
700	554	68	53	18	13	8	7	1	15885
750	592	71	54	19	13	8	7	1	16585
800	629	71	55	19	13	8	7	1	17270
850	667	73	57	20	14	8	7	1	17973
900	704	74	58	20	14	8	7	1	18660
950	742	76	59	21	14	8	7	1	19360
1000	779	77	60	21	15	8	7	1	20050
1050	831	78	61	21	15	8	8	2	20748
1100	868	79	61	21	15	9	8	2	21430
1150	906	80	62	22	15	9	8	2	22135
1200	943	81	63	22	15	9	8	2	27820
1250	981	83	64	23	16	9	8	2	23523
1300	1018	84	65	23	16	9	8	2	24205
1350	1056	85	66	23	16	9	8	2	24910
1400	1093	85	66	23	16	9	8	2	25590
1500	1168	88	68	24	17	9	8	2	26980
1600	1259	89	69	24	17	11	9	2	28360
1700	1334	91	71	25	17	11	9	2	29750
1800	1409	93	72	25	18	11	9	2	31140
1900	1484	94	73	26	18	11	9	2	32500
2000	1559	97	75	26	18	11	9	2	33810
2100	1634	98	76	27	19	11	9	2	35125
2200	1728	99	77	27	19	12	10	2	36440
2300	1803	101	78	27	19	12	10	2	37750
2400	1878	102	79	28	20	12	10	2	39080
2500	1953	103	81	28	20	12	10	2	40375
2600	2028	103	81	29	20	12	10	2	41630
2700	2103	106	83	29	20	12	10	2	42860
2800	2178	107	84	29	21	12	10	2	44090
2900	2253	109	85	30	21	12	10	2	45320
3000	2386	110	86	30	21	15	12	2	46550
3250	2374	113	88	31	22	15	12	2	49643
3500	2761	116	90	32	22	15	12	3	52710
3750	2949	119	93	33	23	15	12	3	55793
4000	3136	122	95	33	23	15	12	3	58720
4250	3324	124	96	34	24	15	12	3	61540
4500	3516	127	99	35	24	15	12	3	64420



ANCHOR WT	WEIGHT N-STOCK	A	B	C	D	F	H	G	PROOF TEST
4750	3699	129	101	35	25	15	12	3	67165
5000	3886	131	102	36	25	15	12	3	69970
5250	4145	133	103	36	26	17	13	3	72790
5500	4332	135	105	37	26	17	13	3	75511
5750	4520	137	107	38	26	17	13	3	78028
6000	4707	139	109	38	27	17	13	3	80600
6250	4895	141	110	39	27	17	13	3	83164
6500	5082	143	111	39	27	17	13	3	85824
6750	5270	144	112	40	28	17	13	3	86154
7000	5457	146	114	40	28	17	13	3	90510
7250	5645	148	115	40	28	17	13	3	92879
7500	5832	150	117	41	29	17	13	3	95283
7750	6020	151	118	41	29	17	13	3	97497
8000	6207	153	119	42	29	17	13	3	99760
8250	6327	154	120	42	30	19	14	4	102033
8500	6714	156	122	43	30	19	14	4	104310
8750	6902	157	123	43	30	19	14	4	106413
9000	7089	159	124	43	31	19	14	4	108563
9250	7277	160	125	44	31	19	14	4	110727
9500	7464	162	126	44	31	19	14	4	112831
9750	7652	163	127	45	31	19	14	4	114789
10000	7839	164	128	45	32	19	14	4	116730

Intermediate sizes may be furnished on request.
Dimensions above are in inches, anchor weight in pounds.



P. O. Box 596 (90748) • 910 Mahar Ave., Wilmington, CA 90744
(800) 322-3131 • (310) 522-9698 • Fax: (310) 522-1043
E-Mail: sales@watermansupply.com
www.watermansupply.com
TradeNet ID 61935