

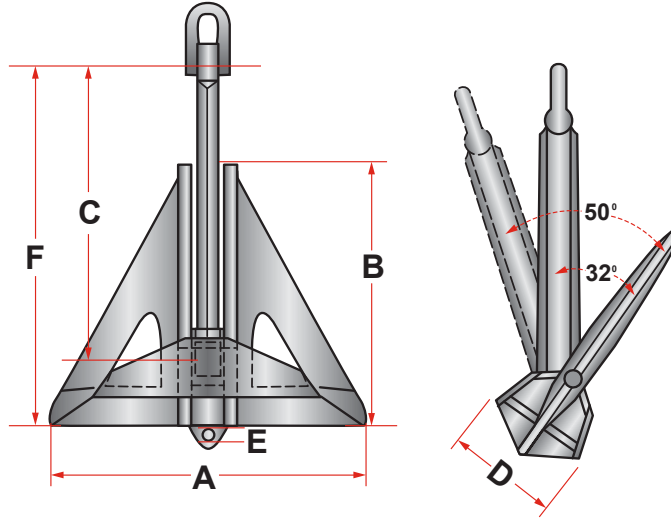

# ANCHORS

## DELTA ANCHOR SUPERIOR HOLDING POWER



### APPROXIMATE WEIGHTS AND DIMENSIONS

ANCHOR WT IN KG	DIMENSIONS IN MM						SHACKLE DIA.	EYE
	A	B	C	D	E	F		
1000	1960	1560	1755	740	45	2605	52	50
1500	2250	1800	2025	840	45	2660	60	50
2000	2470	2000	2250	930	50	2960	70	60
2500	2660	2130	2395	1005	52	3150	70	60
3000	2830	2285	2565	1070	55	3380	80	60
3500	3000	2400	2700	1120	55	3550	80	70
4000	3180	2560	2880	1190	65	3790	90	60
5000	3300	2660	2995	1260	75	3945	100	70
6000	3560	2870	3230	1345	75	4250	100	80
7000	3750	2995	3365	1405	78	4440	110	90
7500	3850	3080	3465	1435	85	4565	110	90
9000	4130	3320	3735	1550	85	4925	125	100
10000	4270	3400	3825	1600	85	5040	125	100
12000	4530	3600	4050	1705	90	5335	130	110
13500	4670	3730	4195	1765	90	5535	140	110
15000	4845	3875	4355	1830	90	5735	140	120
18000	5265	4120	4635	1935	105	6110	150	120
20000	5410	4320	4860	2010	105	6405	160	130
22500	5490	4360	4905	2060	105	6470	170	140
27500	5980	4785	5385	2245	120	7095	180	140
32500	6200	4930	5540	2310	120	7320	165GP	150
40000	6650	5290	5945	2480	120	7850	175GP	150
50000	7150	5690	6390	2670	130	8440	195GP	180
60000	7600	6040	6800	2830	140	9000	210GP	190
75000	8200	6560	7380	3100	150	9430	220GP	220



P. O. Box 596 (90748) • 910 Mahar Ave., Wilmington, CA 90744

(800) 322-3131 • (310) 522-9698 • Fax: (310) 522-1043

E-Mail: [sales@watermansupply.com](mailto:sales@watermansupply.com)

[www.watermansupply.com](http://www.watermansupply.com)

TradeNet ID 61935