

VIKING LIFE-SAVING EQUIPMENT, INC.

## INFLATABLE BUOYANT APPARATUS (IBA)

For passenger ships and ferries operating in inland and coastal waters.



The direct boarding liferaft concept is ideal for vessels with deck heights too low for traditional mass evacuation systems. The open reversible (non-canopied) liferaft is designed for use in protected waters covered by SOLAS HSC (High Speed Craft) regulations or in domestic waters covered by national regulations.

### Capacities

Standard IBA's are available in the following sizes: 12, 20, 25, 50, 100 and 150 persons.

### Packing

Each unit is packed in a reinforced fiberglass container and delivered with galvanized metal cradle and hydrostatic release. A low profile container is available for 12 DKR and 25 DKR.

### CONTAINER

### LIFERAFT

#### 25 DKR, Open reversible liferaft (IBA)

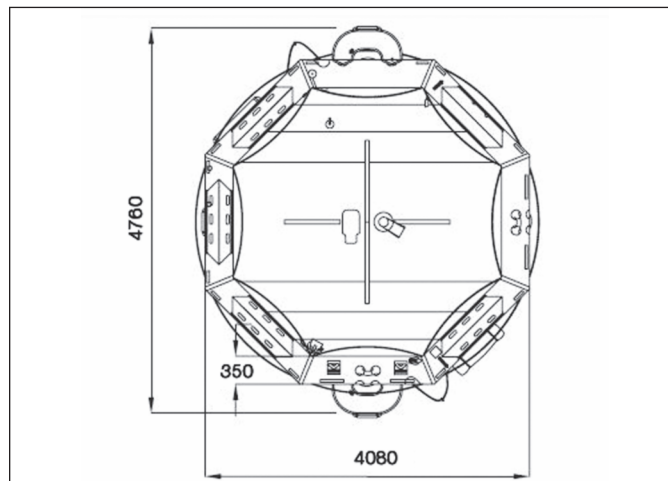
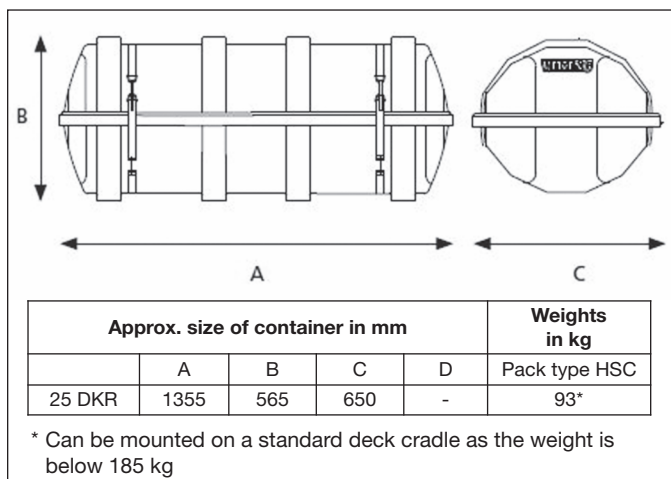

#### 100 DKR, Open reversible liferaft (IBA)

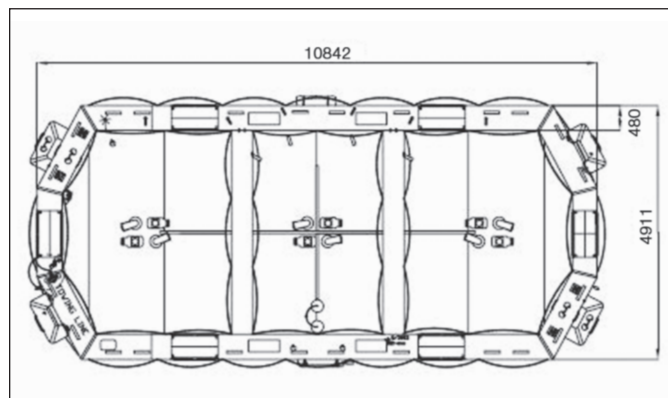
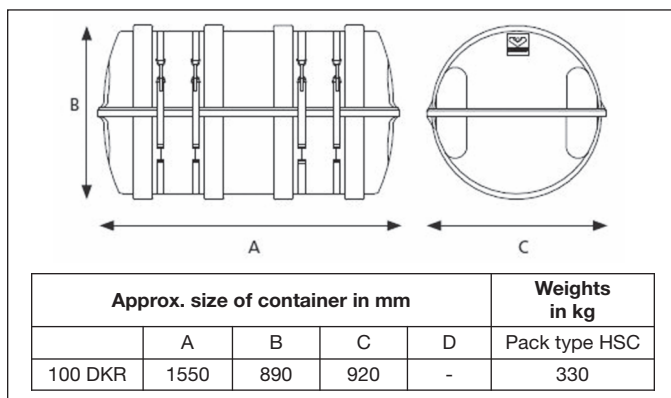

270 Certified Servicing Stations worldwide – See [www.VIKING-life.com](http://www.VIKING-life.com)  
**VIKING LIFE-SAVING EQUIPMENT (America), Inc.**

11255 NW 106 St. Suite 1, Miami, FL 33178 USA  
 Tel: +1 786 513 9900 • Fax: +1 786 513 9910  
[usasales@viking-life.com](mailto:usasales@viking-life.com) • [www.VIKING-life.com](http://www.VIKING-life.com)

(Specifications subject to change without notice.)

