

MMC INTERNATIONAL CORP.

## C-L COUPLINGS with Built-in Safety Ratchet Lock

Ratchet C-L couplings provide quick, safe connections on a wide range of applications: Both marine and dockside hoses, manifolds, loading arms, valves. Each corrosion-resistant coupling (depending on its diameter) contains from three to ten helical cams.

Each ratchet cam is individually locked into place so that it cannot be loosened without a special wrench (see below). A typical 3-cam connection is completed in less than a minute. (4" – 20" available)

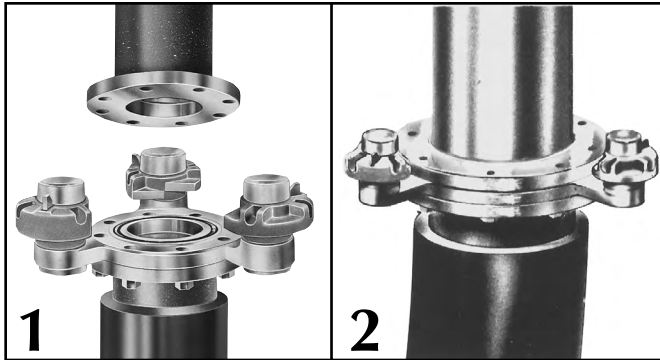

Here a ratchet C-L coupling (studded configuration) is bolted to an existing ASA hose flange for a one-time permanent installation. The coupling is then ready to be joined to a matching flanged hose, manifold or pipe of comparable diameter.

Secure the matching flange to the C-L coupling by rotating each cam to a hard stop using the bronze spanner wrench which is supplied.

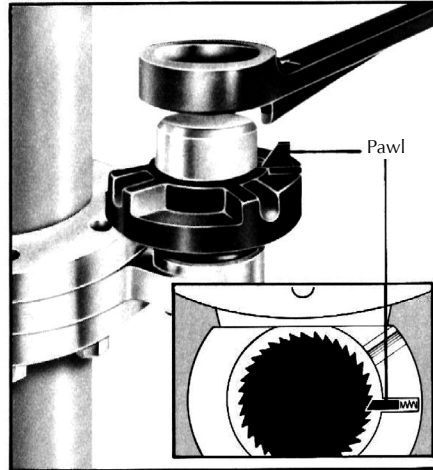

### Each cam locks safely in place

When the mating flange is inserted into the coupling, each helical cam is tightened with this supplied wrench which activates a built-in ratchet lock (see inset). When the wrench is removed, the pawl grips tightly against the ratchet teeth, preventing the cam from turning back and loosening. To open the coupling, the collar on the wrench disengages the pawl from the ratchet, which then allows the cam to rotate counter-clockwise, release the flange

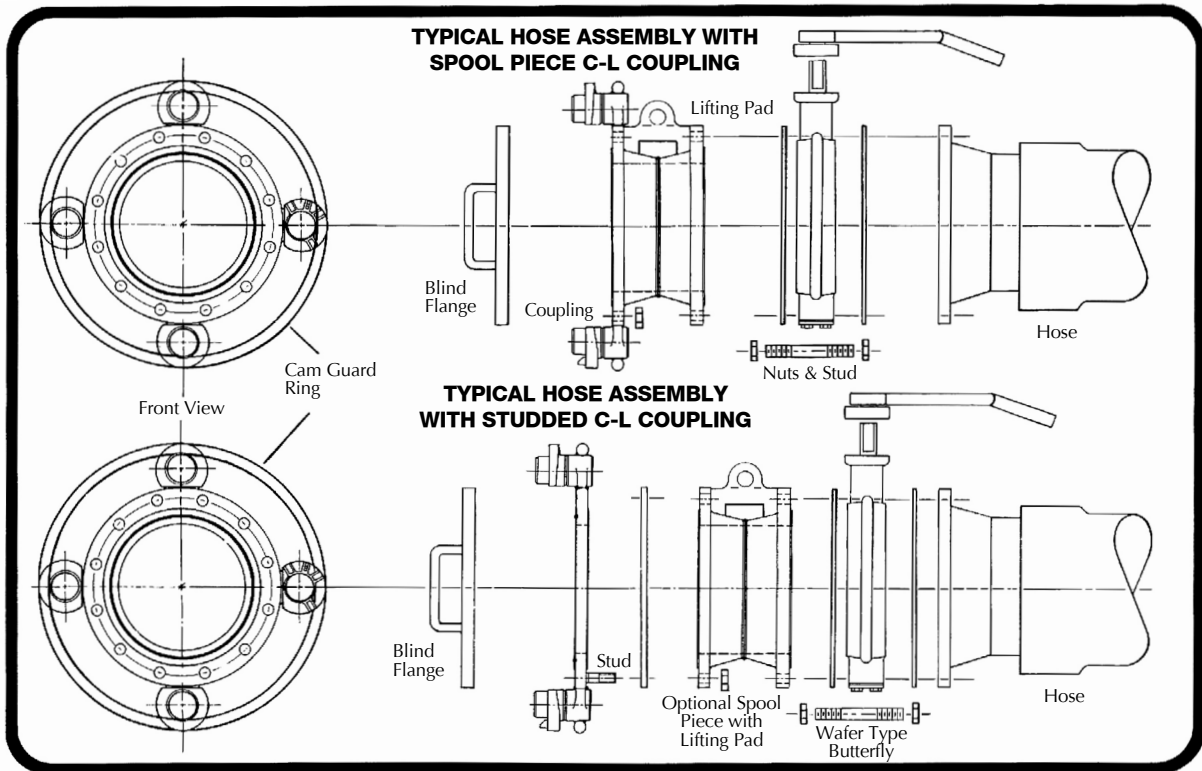

Also see the



Web Site – [www.cl-flange.com](http://www.cl-flange.com) –  
for “Floating Hose” Couplings  
TradeNet ID 52539

#### MMC International Corporation

60 Inip Drive  
Inwood, NY 11096-0664 U.S.A.  
Phone: 1-800-645-7339  
Fax: 1-516-371-3134  
E-mail: [info@mmcintl.com](mailto:info@mmcintl.com)  
Web Site: <http://www.mmcintl.com>

#### MMC (Europe) Ltd.

So. Nelson Rd., So. Nelson Industrial Estate  
Cramlington, Northumberland  
NE23 9WF UK  
Phone: (01670) 738111  
[info@mmc-europe.co.uk](mailto:info@mmc-europe.co.uk)  
Fax: (01670) 738789

#### MMC (Asia) Ltd.

7-7, 2-Chome  
Kotonoo-Cho  
Chuo-ku, Kobe 651 Japan  
Phone: (078) 251-0061  
[info@mmcasia.co.jp](mailto:info@mmcasia.co.jp)  
Fax: (078) 252-0265