

STI MARINE

Collar Dimensions for Marine Firestop Collars

SIZES 16 – 40

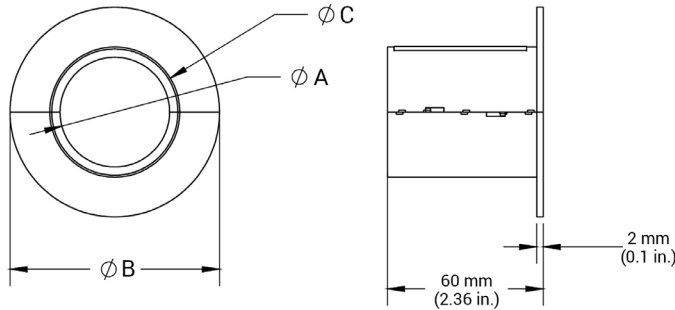

Size	A		B		C		Opening Needed	
	mm	in	mm	in	mm	in	mm	in
16	16	0.6	56	2.2	26	1.0	30	1.2
20	20	0.8	60	2.4	30	1.2	30	1.2
25	25	1.0	65	2.6	35	1.4	30	1.2
32	32	1.3	72	2.8	42	1.7	45	1.8
40	40	1.6	80	3.1	50	2.0	50	2.0

SIZES 50 - 324

Size	A		B		C		D		E	
	mm	in	mm	in	mm	in	mm	in	mm	in
50	50	2.0	126	5.0	79	3.1	55	2.15	60	2.4
60	60	2.4	138	5.4	91	3.6	55	2.15	70	2.8
63	63	2.5	141	5.6	93	3.7	55	2.15	73	2.9
75	75	3.0	153	6.0	105	4.1	55	2.15	85	3.3
90	90	3.5	167	6.6	119	4.7	55	2.15	100	3.9
110	110	4.3	186	7.3	139	5.5	55	2.15	120	4.7
115	115	4.5	191	7.5	144	5.7	55	2.15	125	4.9
125	125	4.9	203	8.0	156	6.1	105	4.12	135	5.3
140	140	5.5	218	8.6	171	6.7	105	4.12	150	5.9
160	160	6.3	238	9.4	191	7.5	105	4.12	170	6.7
169	169	6.7	247	9.7	200	7.9	105	4.12	179	7.0
200	200	7.9	334	13.1	242	9.5	131	5.15	210	8.3
219	219	8.6	353	13.9	261	10.5	131	5.15	229	9.0
225	225	8.9	354	13.9	267	10.5	131	5.15	235	9.3
273	273	10.7	404	15.9	315	12.4	131	5.15	283	11.1
324	324	12.8	457	18.0	366	14.4	131	5.15	334	13.1

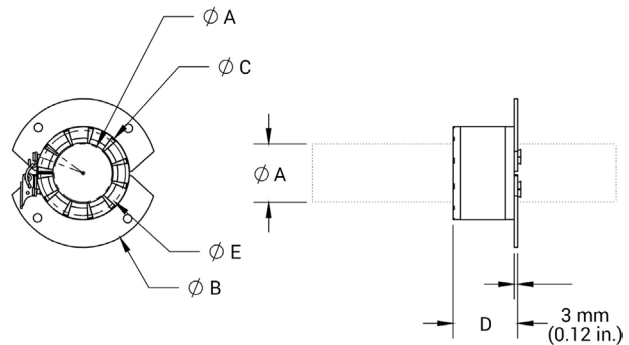

EAST COAST
Branchburg, NJ
Tel: 732.247.2300
Fax: 732.247.7258

GULF COAST
Houston, TX
Tel: 713.682.2400
Fax: 713.682.2624

SOUTHEAST
Davie, FL
Tel: 954.321.0784
Fax: 954.321.2591

WEST COAST
Paramount, CA
Tel: 562.633.4141
Fax: 562.633.3280