

KENNEDY PROFESSIONAL Insulated Spanners

Chrome vanadium single ended open jaw spanners. Spanner dimensions conform to **DIN 7446**. Fully insulated to conform to **VDE 0680/201** and **EN 60900:2012** standards for safe electrical applications up to 1000V.

Single End Open Jaw



Size	Weight each	Order Code KEN-534
10mm	30g	-8800K
11mm	45g	-8810K
12mm	60g	-8820K
13mm	60g	-8830K
14mm	70g	-8840K
15mm	85g	-8850K
16mm	115g	-8860K
17mm	110g	-8870K
18mm	135g	-8880K
19mm	150g	-8890K
21mm	205g	-8910K
24mm	250g	-8940K

Insulated Single End Ring Spanners



Size	Weight each	Order Code KEN-534
10mm	85g	-9200K
11mm	110g	-9210K
12mm	120g	-9220K
13mm	125g	-9230K
14mm	175g	-9240K
15mm	135g	-9250K
16mm	175g	-9260K
17mm	190g	-9270K
18mm	220g	-9280K
19mm	250g	-9290K
21mm	310g	-9310K
22mm	325g	-9320K
24mm	340g	-9340K

Insulated Adjustable Wrenches

Manufactured from chrome vanadium steel with hardened parallel opening jaws that are ground and polished, laser etched with metric graduations for rapid repeatable reference setting. Knurled adjusting screw ensures smooth adjustment. Fully insulated, conforms to **EN 60900:2012** standards for safe electrical applications up to 1000V.



Overall Length	Capacity	Weight each	Order Code KEN-534
200mm	24mm	336g	-6080K
250mm	30mm	551g	-6100K
300mm	34mm	870g	-6120K

AITL Insulated Adjustable Spanner

Volt-tested to ensure safety on or near electrical equipment up to 1000V. Nylon 11 injection moulded insulation. Accredited to: **IEC60900:2004**. Category C impact tested.



Product Number	Overall Length	Weight	Order Code INS-501
03000	203mm (8")	235gm	-1080B

Insulated Pump/Box Joint Pliers

Hardened chromed steel jaws. Sliding pivot joint allows the widest range of jaw openings. Serrated jaws for gripping flat and round parts. The handles cannot be closed together, preventing trapped fingers.



Fully insulated, conforms to **EN 60900:2012** standards for safe electrical applications up to 1000V.



Overall Length	Weight each	Order Code KEN-534
240mm	55g	-4860K

Insulated Tweezers

Straight/bent pattern tweezers with serrated gripping surfaces, quality tested and insulated to 1000V AC. Conforms to **EN 60900:2012** standards.

Exposed blade length: 15mm.



Straight Pattern



Bent Pattern



Overall Length	Type	Weight each	Order Code KEN-534
145mm	Straight	40g	-1120K
145mm	Curved	40g	-1140K

Insulated Hacksaw

Die cast frame with 'D' style handle for user comfort and control. Wing nut blade tensioning. Supplied complete with 300mm 24tpi blade. Fully insulated, conforms to **EN 60900:2012** standards for safe electrical applications up to 1000V.

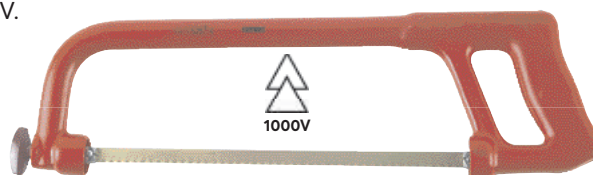

Overall Length	Weight each	Order Code KEN-534
400mm	619g	-0800K

Insulated Junior Hacksaw

Tested and insulated to 1000V AC and 1500V DC for live line working. All insulation is moulded in one piece. Uses conventional junior hacksaw blades. **EN 60900:2012**.



Overall Length	Weight each	Order Code KEN-534
150mm (6")	264g	-0600K

Insulated Junior Hacksaw

Fixed 6" (150mm) blade. Volt-tested to ensure safety on or near electrical equipment up to 1000V. Nylon 11 injection moulded insulation. Accredited to: **IEC60900:2004**. Category C impact tested.



Product Number	Overall Length	Weight	Order Code INS-538
01810	270mm	145g	-2060A

KENNEDY PROFESSIONAL Insulated Ratcheting Cable Cutter

For copper and aluminium cables up to 32mm diameter. Lightweight steel handles with insulated vinyl hand grips. Fixed and moving blade made from high grade alloy steel. Quality tested **EN 60900:2012** and insulated to 1000V AC.



Overall Length	Weight each	Order Code
250mm (10")	678g	-5000K

Insulated Cable Cutters

Manufactured from drop forged high carbon steel with induction hardened blades. Fully insulated to conform with **VDE 0680/201** and **EN 60900:2012** standards for safe electrical applications up to 1000V.



Overall Length	Capacity	Weight each	Order Code
240mm	22mm	398g	-4960K

Insulated Cable Knives

Fully insulated to conform to **VDE 0680/201** and **EN 60900:2012** standards for safe electrical applications up to 1000V.



Overall Length	Type	Weight each	Order Code
180mm	Curved Blade	65g	-3480K
180mm	Straight Blade	65g	-3500K

Insulated Dismantling Cable Knife

Insulated dismantling cable knife complete with protection cap. Quality tested to 1000V AC. Comfortable handle, fixed sickle shaped blade for cutting sector cables. Conforms to **VDE 0680/201** and **EN 60900:2012** standards.

Blade length: 45mm.



Overall Length	Weight each	Order Code
180mm	70g	-3540K

AITL Insulate Cable K

Volt-tested to ensure safety on or near electrical equipment up to 1000V. Nylon 11 injection moulder insulation. Accredited to: **IEC60900:2004**. Category C impact tested.



Product Number	Length	Weight each	Order Code
01830	175mm	120gm	-3010A

Insulated Sockets & Accessories

All products are quality tested and fully insulated to 1000V AC. Conforms to **VDE 0680/201** (except extension bars) and **EN 60900:2012** standards. All 1/2" square drive.

Insulated Reversible Ratchet Handle



Weight each	Order Code
660g	-7400K

200mm Insulated T-Handle



Weight each	Order Code
450g	-7420K

125 & 250mm Insulated Extension Bars



Description	Weight each	Order Code
125mm Extension Bar	200g	-7440K
250mm Extension Bar	270g	-7460K

Insulated Single Hexagon Sockets



Type	Size	Overall Length	Weight each	Order Code
Metric	10mm	37	60g	-7500K
	11mm	37	60g	-7510K
	12mm	37	60g	-7520K
	13mm	37	70g	-7530K
	14mm	37	60g	-7540K
	15mm	37	60g	-7550K
	16mm	37	70g	-7560K
	17mm	37	80g	-7570K
	18mm	37	90g	-7580K
	19mm	37	90g	-7590K
	20mm	37	100g	-7600K
	21mm	37	95g	-7610K
	22mm	37	105g	-7620K
24mm	37	135g	-7640K	

Order online at cromwell.co.uk or call

North **0800 028 3602** | Central **0800 028 3191** | South **0800 028 3189**

KENNEDY PROFESSIONAL 1000V Dual Grip VDE Screwdrivers

A fully insulated screwdriver VDE tested up to 1000V. Professional high grip handles, magnetic tips, chrome vanadium steel blades.



Crosspoint

Crosspoint screws virtually eliminate the screwdriver slippage if the correct size is used. The No.2 driver is suitable for most applications.



Tip Size	Blade Length	Weight each	Order Code KEN-572
No.0	60mm	20g	-7900K
No.1	80mm	60g	-7910K
No.2	100mm	90g	-7920K

Parallel Tip

Slotted head screws are the most commonly used screw. To safely drive these screws, the tip of the screwdriver should be of the same width as the slot in the screw head and fill it as well, to minimise slipping and deforming the screw head.



Tip Size	Blade Length	Weight each	Order Code KEN-572
2.5mm	75mm	20g	-7940K
4.0mm	100mm	60g	-7950K
5.5mm	125mm	75g	-7960K
6.5mm	150mm	110g	-7970K

Set Contents:

2.5 x 75,
4.0 x 100,
5.5 x 125,
6.5 x 150mm.



No.0 x 60,
No.1 x 80,
No.2 x 100mm.

7
PIECES



Weight each

Order Code KEN-572

715g

-8000K



Electrician's VDE Square Section Handle Screwdrivers

Volt-tested to ensure safety on or near electrical equipment up to 1000V AC or 1500V DC. Insulated blades with magnetic tips. Conform with DIN 7438 and DIN EN 60900.

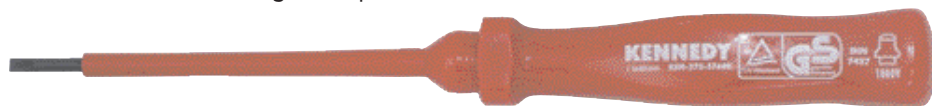

Crosspoint

Crosspoint screws virtually eliminate the screwdriver slippage if the correct size is used. The No.2 driver is suitable for most applications.



Tip Size	Blade Length	Weight each	Order Code KEN-572
No.0	75mm	27g	-5820K
No.1	100mm	50g	-5830K
No.2	100mm	80g	-5840K

Parallel Tip

Slotted head screws are the most commonly used screw. The tip of the screwdriver should be of the same width as the slot in the screw head and fill it as well, to minimise slipping.



Tip Size	Blade Length	Weight each	Order Code KEN-572
2.5mm	85mm	30g	-5760K
4.0mm	100mm	45g	-5780K
5.5mm	125mm	80g	-5790K
6.5mm	150mm	100g	-5800K

Set Contents:

Supplied in clear plastic wallet.
2.5 x 85,
4.0 x 100,
5.5 x 125,
6.5 x 150mm.



No.0 x 75,
No.1 x 100,
No.2 x 100mm.

7
PIECES



Weight each

Order Code KEN-572

495g

-5900K



Insulated Interchangeable Screwdriver Set

Ergonomic, insulated, full size handle, swivel cap and eight interchangeable drivers supplied in a compact protective pouch with belt loop. 2-in-1 design, use the detachable swivel cap for fast (low torque) driving, or use the full size detachable ergonomic handle for higher torque fastening. Safe up to 1000V AC/1500V DC.



10 Piece Set Contents (mm):

0.4 x 2.5 x 100mm,
0.5 x 3.0 x 100mm,
0.8 x 4.0 x 100mm,
1.0 x 5.5 x 100mm and
6.5 x 100mm.



No.0 x 100mm,
No.1 x 100mm and
No.2 x 100mm.



10
PIECES



Weight each
365g

Order Code KEN-572
-5870K



Insulated Screwdriver

3mm parallel tip. Volt-tested to ensure safety on or near electrical equipment up to 1000V. Nylon 11 injection moulded insulation. Accredited to: IEC60900:2004. Category C impact tested.



Product Number	Blade Length	Overall Length	Weight each	Order Code
01870	100mm	175mm	20gm	INS-572 -1004B

STANLEY FatMax® Insulated Screwdriver Set

100% individually tested to 1,000V. Soft grip handle. Chrome vanadium steel bar allows for high torque and reduces the chance of tip breakage.

10
PIECES



Product Number
5-62-573

Order Code STN-572
-1078X

KENNEDY PROFESSIONAL Pro-Torq Insulated Pliers

Especially suitable for production line environments where repetitive work is undertaken. Double polished head and joint with induction hardened cutting edges.



VDC/IEC 900
DIN EN 60900

Insulated End Wire Strippers



Overall Length	Weight each	Order Code
160mm (6 ³ / ₈ "	199g	KEN-558
		-5200K

Insulated Diagonal Cutting Nippers



Overall Length	Weight each	Order Code
160mm (6 ³ / ₈ "	205g	KEN-558
205mm (8")	262g	
		-5100K
		-5120K

Insulated Snipe Nose Pliers



* Bent nose

Overall Length	Weight each	Order Code
160mm (6 ³ / ₈ "	157g	KEN-558
205mm (8")	221g	
205mm (8")*	212g	
		-5020K
		-5040K
		-5060K

Insul



Overall Length	Weight each	Order Code
160mm (6 ³ / ₈ "	226g	KEN-558
180mm (7")	290g	
205mm (8")	344g	
		-5140K
		-5160K
		-5180K

ITL Insulated Combination Pliers

Side Cutter, Burner Hole and Facets. Volt-tested to ensure safety on or near electrical equipment up to 1000V. Nylon 11 injection moulded insulation. Accredited to: IEC60900:2004. Category C impact tested.



Product Number	Overall Length	Weight each	Order Code
00021	200mm	310g	INS-558
			-2200E

Insulated Socket Set 1/2" Sq. Dr. AF/Metric Socket

03095

1/2 Fully insulated socket set with a range of 16 sockets, a reversible ratchet and a 5" and 10" extension bar. Supplied in a black case with foam 'tool control' insert. Manufactured to IEC 600900:2004, Category 'C'.

Set contents: reversible ratchet handle, 5 and 10" extension bars; sockets 8, 10, 13, 17, 19, 20, 22 and 25mm; AF 3/8", 7/16", 1/2", 9/16", 3/4", 7/8", 15/16" and 1".



19
PIECES

Product Number	Order Code
03095	INS-582
	-6090Y

Insulated General Purpose Tool Kit

00007

General purpose insulated tool kit supplied in a black case with foam 'tool control' insert. Manufactured to IEC 600900:2004, Category 'C'.

Set contents: 8" engineer's combination pliers, 6" diagonal cutting nippers, 8" long snipe nose pliers, 7" cable jointer's coring knife, 3" terminal screwdriver 1/8" (3mm), 3" electrician's screwdriver 5/32" (4mm), 6" insulated screwdrivers 3/16" (5mm), 5/16" (8mm), No. 1/2 Philips screwdrivers, reversible ratchet handle, 5 and 10" extension bars and insulated sockets (1/2" sq. dr.): 10 - 14, 17 and 19mm, hex keys: 5 and 6mm, open ended spanners: 10 - 14, 17 and 19mm.

29
PIECES



Product Number	Order Code
00007	INS-595
	-1007H

Electrician's VDE Tool Bag & Kit

Heavy duty tear-resistant tool bag with velcro fastening flap. Double-webbed shoulder strap fixed with metal release clasps. Two removable tool boards inside which have a unique tool storage securing system built-in. All tools are VDE approved.

Contents:

Electrician's tool bag (320 x 340 x 125mm). 150mm euro tester will detect 'live' electricity supply. Suitable for AC to 125 - 250V. 3mm wide tip. Conform to VDE 0630 Part 4. 145mm (5³/₄") Pro-Torq grip diagonal nipper 1000V insulated. 160mm (6³/₈") Pro-Torq snipe nose plier 1000V insulated. 165mm (6¹/₂") Pro-Torq engineer's combination plier 1000V insulated. 170mm (6³/₄") Pro-Torq wire stripper 1000V insulated. 7-pce VDE dual grip screwdriver set: No.0 x 60, No.1 x 80 and No.2 x 100mm, 2.5 x 75, 4.0 x 100, 5.5 x 125 and 6.5 x 150mm. 180mm (7") insulated cable knife, curved blade. 2x small parts storage boxes.

16
PIECES



Width (mm)	Depth (mm)	Height (mm)	Weight each	Order Code
320	125	340	3.50kg	KEN-595
				-3400K

Insulated Diagonal Cutting Nippers

Volt-tested to ensure safety on or near electrical equipment up to 1000V. Nylon 11 injection moulded insulation. Accredited to: IEC60900:2004. Category C impact tested.



Product Number	Overall Length	Weight each	Order Code
00101	160mm	205g	INS-558
			-5100J

Order online at cromwell.co.uk or call

North 0800 028 3602 | Central 0800 028 3191 | South 0800 028 3189

1013

Safety Level

Safety Knives

- Ultimate** 5
Recessed blade (pages 1015 - 1016)
 Designed specifically to maximise user safety. The blade is recessed and concealed in the knife body making it almost impossible to touch.
- Very High** 4
Ceramic blade (page 1017)
 Safer than traditional blades and last longer than steel blades.
- High** 3
Restricted blade depth (page 1018)
 The blade only comes out a certain amount.
- Very Good** 2
Auto return blade (page 1019)
 Also known as a Smart knife, the blade retracts when the slide button or lever is released or automatically when losing contact with the material being cut.
- Good** 1
Spring return blade (page 1020)
 The blade retracts when the slide button or lever is released.



Recessed blade (pages 1015 - 1016)



Ceramic blade (page 1017)



Restricted blade depth (page 1018)



Auto return blade (page 1019)



Spring return blade (page 1020)

Utility Knives

Manual return blade (page 1021)
 The blade is manually retracted into the handle.

Fixed blade (page 1022)
 No retraction or safe covering.

Snap-off blade (pages 1024 - 1025)
 Blade can be snapped off when blunted to reveal a new sharp edge.



Manual return blade (page 1021)



Fixed blade (page 1022)



Snap-off blade (pages 1024 - 1025)















You must be 18 or over to purchase knives & blades

Age Requirements for Specific Goods such as solvents, axes, knives and knife blades, carry restrictions relating to sales.

We therefore have additional processes in place to ensure that sales will only be made in accordance to the requirements and you may be asked to validate that your address for delivery is to a named business location.

Online sales are restricted and if you are making the purchase in one of our sales locations please do not be offended if you are requested to provide proof of age.

For more information please see our Age Restricted Goods Policy on www.cromwell.co.uk

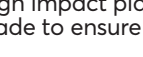
Safety level 5 Ultimate		Safety Level 5 Ultimate	Pull Cutter	Push Cutter	One Cutting Edge	Two Cutting Edges	Disposable	Replacement Head	Replacement Blade	Tape Splitter	Scraper	Lockable Blade Change	Tether Point	Spare Blade Storage	Staple Remover	Soft Grip	Order Code	Page
	Avon	•	•		•		•						•				AVN-537-0020K	1015
	Avon	•	•		•				•	•				•	•		AVN-537-0030K	1015
	Avon	•		•	•		•			•			•				AVN-537-0010K	1015
	Martor	•	•		•			•					•	•			MRR-537-7550B	1015
	Martor	•	•			•	•				•		•				MRR-537-7549A	1015
	Stanley	•	•		•				•				•				STN-585-2462G	1016
	Stanley	•	•		•				•	•			•			•	STN-585-9086N	1016
	Stanley	•	•		•			•		•			•			•	STN-585-9078D	1016
	Stanley	•	•		•		•			•			•			•	STN-585-9133J	1016
	Stanley	•	•			•		•		•			•			•	STN-585-9079E	1016
	Stanley	•	•			•	•			•			•			•	STN-585-9137N	1016
	Martor	•	•			•	•						•				MRR-537-7575G	1016
	Martor	•	•		•				•	•			•				MRR-537-3340T	1016
	Martor	•	•		•				•	•			•		•		MRR-537-7549R	1016
	Senator	•	•		•		•										SEN-537-2000K	1016
	Martor	•		•	•				•								MRR-537-5803C	1016

AVON Disposable Cutting Safety Knife

High impact plastic handle with enclosed blade to ensure maximum user safety.



Priced per knife

Overall Length	Order Code
154mm	AVN-537-0020K

Carton Opener

For cutting through loading straps, extracting staples and slitting tape without damaging the contents. In-handle blade storage. Spring loaded blade guard, retractable slitting blade, complete with spare blade.



Overall Length	Order Code
190mm	AVN-537-0030K

Fish 2000 Safety Knife

Has an enclosed blade within a 4.7mm gap and an auto-retracting hook blade.



Priced per knife

Overall Length	Order Code
155mm	AVN-537-0010K

Safety Knife

SECUMAX 350 - 350001
Concealed blade with a 6 mm cutting depth. Ergonomic shape including soft grip. Maximum safety with spare blade in handle
Dimensions: L 154mm x W 12mm x H 40mm



Weight	Order Code
37g	MRR-537-7550B

Disposable Safety Knife

SECUMAX 150 - 150001
For use with cardboard (up to double-walled), films (stretch film and shrink wrap), adhesive tape, thin plastic box strappings, goods bagged in film or paper and cords.
Overall length: 150mm



Overall length	Order Code
150mm	MRR-537-7549A

STANLEY Safety Wrap Cutter

0-10-244

Shrink wrap cutter for opening pallets and boxes/ strapping. Large handle - for ease of use. Finger guard for safety.



Description Order Code

Safety Wrap Cutter -2462G
Safety Cutter Blades -2462H

Replaceable Double-Sided Blade Pull Cutter

FMHT10373

Lightweight. Uses standard knife blades. Cuts through single and double wall corrugate cardboard. Slip-resistant bi-material grip



Order Code
STN-585

-9086N

FatMax® Replaceable Head Pull Cutter

FMHT10358-0

Lightweight. Single-sided replaceable blade head. Slip-resistant bi-material grip. Tape splitter.



Description

Order Code
STN-585

Body & Head

-9078D

20 heads

-9087P

Single-Sided Round Tip Pull Cutter

STHT10357

Lightweight. Slip-resistant bi-material grip. Lanyard hole. Ideal for cutting through shrink wrap and film.



QTY
10

Order Code
STN-585

-9133J

martor Secumax Easysafe

121001

- Tool-less blade change
- Abrasion resistant
- Very ergonomic
- 4-times usable blade
- Tape splitter
- For right and left hander
- Lanyard hole



Order Code

MRR-537

-3340T

FatMax® Replaceable Head Pull Cutter

FMHT10361-0

Lightweight. Double-sided replaceable blade head. Slip-resistant bi-material grip. Tape splitter.



Description

Order Code
STN-585

Body & Head

-9079E

20 heads

-9088Q

Double-Sided Bi-Material Pull Cutter

- Lightweight double-sided bi-material pull cutter
- Optimized cutting depth cuts through single/double wall corrugate
- Metal tape splitter.



QTY

Order Code
STN-585

10

-9137N

martor Disposable Safety Knife

SECUMAX 145 - 145001

Concealed blade, disposable knife. Lightweight, ultra tough. 2 in 1 blade for cutting and piercing.

Dimensions: L 118 x W 4 x H 35.4mm.



Description

Order Code
MRR-537

Safety Knife

-7575G

martor Secumax Round Blade Safety Knife

A rounded nose safety knife that's strong, robust and long lasting.

- You can then directly access the 4-cutting edge blade
- New handle shape with the finger friendly contours will fit in your hand
- Pre-set cutting angle



Overall Length

Order Code
MRR-537

158mm

-7549R

SENATOR Disposable Carton & Strap Cutter

The blade is partially exposed to prevent accidental cuts.



Overall Length

Order Code
SEN-537

80mm

-2000K

martor Secumax Opticut Safety Cutter

No.437

Teflon-coated, metal foot, easy to slide. Ideal for 'push' cutting.



Size (L x W x H) mm

Order Code
MRR-537

113 x 19 x 84.5

-5803C

Safety level 4 Very High		Safety Level 4 Very High	Finger friendly blade	Ambidextrous	Disposable	Auto return blade	Spring return blade	Manual return blade	Fixed blade	Internal blade storage	Push slider	Pull slider	Built in magnet	Key ring hole	Lanyard hole	Order Code
	Slice	•	•	•			•				•				•	SLC-537-1050D
	Slice	•	•	•			•				•				•	SLC-537-1051D
	Slice	•	•	•		•						•			•	SLC-537-1069A
	Slice	•	•	•			•				•				•	SLC-537-1068P
	Slice	•	•	•				•			•				•	SLC-537-1067H
	Slice	•	•	•			•				•				•	SLC-537-1053H
	Slice	•	•	•	•				•				•	•		SLC-537-0020A

Ceramic technology
Finger friendly
Lasts up to 10x longer than steel
Fewer blade changes



Less downtime
Lower costs
A safer working environment

slice™ Utility Knife
10558
Auto return blade. A durable glass-filled nylon handle. Ergo Pull™ reduces strain allowing you to slide and cut in the same direction.



Description	Order Code
Knife	-1069A
3 spare blades	-1060P

slice™ Mini Cutter
10514
Works as well as a safety box cutter as it does a pocket knife or kitchen multi-tool. Spring return blade. Length 62mm.



Description	Order Code
Knife	-1053H
4 spare blades	-1044D

slice™ Box Cutter
10503
Ergonomic handle. Spring return blade. Suitable for single and double wall cardboard. Length 100mm.



Description	Order Code
Knife	-1050D
4 spare blades	-1044D

Utility Knives
10554
Spring return blade. A durable glass-filled nylon handle. Cuts through thick materials, including triple-walled corrugated cardboard.



Description	Order Code
Knife	-1068P
3 spare blades	-1060P

Safety Cutter
00200
Popular safety cutter in the Slice® range. Cuts thin materials effectively. Suitable for household and industrial settings. Lanyard hole and built-in magnet keeps it close hand.

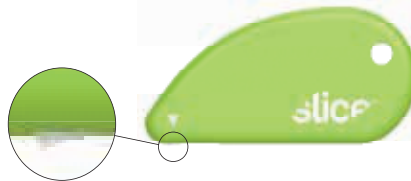

Description	Order Code
Knife	-0020A

Pen Cutter
10512
Its slim cylindrical shape is ideal for hard-to-reach areas. Spring return blade. No-tool blade change and a rubberised slider button.



Description	Order Code
Knife	-1051D
4 spare blades	-1044D

Utility Knives
10550
Manual return blade. Five blade positions. A durable glass-filled nylon handle. Cuts through thick materials, including triple-walled corrugated cardboard.







Description	Order Code
Knife	-1067H
3 spare blades	-1060P

Ceramic Replacement Blades

- 100% Zirconium Oxide
- Straight-rounded tip (10404)
- Straight-pointed tip (10528)

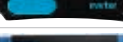
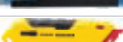

Product number	Qty	Order Code
10404	4	-1044D
10528	3	-1060P

		Safety Level 3 High	Safety Level 1 Good	Auto return blade	Spring return blade	Squeeze trigger	Left handed use	Right handed use	Disposable	Aluminium body	Glass fibre reinforced plastic body	Plastic body	Steel body	Max cutting depth (mm)	Tape splitter	Lanyard hole	Order Code
	Martor	•		•		•	•	•		•				9			MRR-537-5626D
	Martor	•		•		•	•	•			•			9		•	MRR-537-7528K
	Martor	•			•	•	•	•			•			15		•	MRR-537-7550F
	Martor	•			•		•	•	•			•		12		•	MRR-537-7551N
	Martor	•			•		•	•				•	•	9			MRR-537-4323A
	Stanley		•		•	•	•					•			•	•	STN-537-9080F
	Stanley		•		•	•	•					•			•	•	STN-537-9081GF

Martor Auto Blade Retraction Knives

Secupro Martego - 122001

An ergonomic squeeze lever - made out of aluminium and a soft plastic component - provides comfortable and non-slip handling.



Description	Order Code
122001 Cutter	MRR-537-5626D
No 92 Blade - Pk 10	-5636P

Automatic Retraction Safety Cutter

SECUPRO MERAK

Fully automatic blade retraction. One blade, four cutting corners. Safer blade change (with magnet) and a safety lock. Ergonomic squeeze grip. Use: 2-ply cardboard, box topping.

Cutting Depth: 9 mm.

Weight: 76g.



Size (L x W x H) mm	Order Code
215 x 68 x 40	MRR-537-7528K
No 92 Blade - Pk 10	-5636P

Secunorm Mizar

125001

- Spring return blade
- Tool-less blade change
- Abrasion resistant
- Very ergonomic
- Safety lock
- 2-times usable blade
- Extended blade length 22mm
- Cutting depth 15mm
- TÜV-certified
- Dimensions (LXW): 139 x 15.6mm



Description	Order Code
Knife	MRR-537-7550F
No 5232 Blade Pk 10	-1665E

Martor Secunorm Smartcut Safety Knife

110100

Small, light and handy with a double-sided slider. The spring return blade allows you to take your thumb off the slider when cutting and the blade will retract when leaving the material being cut. It is disposable, meaning no risk of injury when changing the blade or losing the blade during the production process.



Overall Length	Order Code
110mm	MRR-537-7551N

Secunorm Handy - 445

A compact yet versatile safety cutter. Suitable for a variety of cutting applications. Length 100mm.



Description	Order Code
445 cutter	MRR-537-4323A
No 45 Blade - Pk 10	-2730H

STANLEY FatMax® Box Top Safety Knife

Lightweight box top safety knife with a spring-loaded blade that retracts automatically when pressure on the squeeze trigger is released.

Features & Benefits

- Box top guide with integrated tape splitter aligns the blade for easy box top removal.
- Easy trigger squeeze technology exposes the blade and helps reduce user strain.
- Three blade depth settings limit blade exposure and help protect contents.
- Blade lock helps prevent accidental blade exposure.
- Slip-resistant bi-material grip for comfort and control.
- Quick, toolless blade change.

Includes: 4 Round Point Utility Blades



Description	Part Number	Order Code
Right hand use	FMHT10363	STN-585-9081G
Left hand use	FMHT10362	-9080F

Safety level 2 Very Good		Safety Level 2 Very Good	Squeeze trigger	Ambidextrous	Aluminium body	Plastic body	Lanyard hole	Strap cutter	Tape splitter	Bi-material grip	Blade depth setting	3 sided slide button	Spare blade storage	Tool-less blade change	Order Code
	Kennedy	•	•	•	•			•	•	•				•	KEN-537-0780K
	Stanley	•	•	•	•		•	•	•					•	STN-585-2462E
	Stanley	•	•	•		•	•			•	3	•	•	•	STN-585-9082H
	Stanley	•	•	•			•			•	3	•	•	•	STN-585-9083J
	Stanley	•	•	•	•		•			•				•	STN-585-9085L
	Martor	•		•	•					•				•	MRR-537-5700E
	Martor	•	•	•	•		•			•				•	MRR-537-7550G

KENNEDY PROFESSIONAL Automatic Retractable Safety Knife/Strap Cutter

Blade automatically retracts when losing contact with surface. Accepts medium, heavy duty and hook blades.



Product Number	Order Code
SX1212	KEN-537
Blades	-0780K
	-7610K

STANLEY FatMax® Safety Knife

Blade automatically retracts when it loses contact with surface. Ideal for opening boxes without cutting contents. Soft grip for comfort.



Product Number	Order Code
0-10-242	STN-585
	-2462E

FatMax® Auto-Retract Tri-Slide Safety Knife

FMHT10365-0
Premium safety knife with an oversized, contoured tri-slide button which can be engaged from three positions (top, left, and right side). Three blade depth settings. Blade lock. With an ergonomic, slip-resistant bi-material grip and quick, tool-less blade change.



Body	Order Code
Plastice	STN-585
Metal	-9082H
	-9083J

FatMax® Auto-Retract Squeeze Safety Knife

FMHT10370-0
Lightweight with an easy trigger squeeze technology which exposes the blade. Blade lock helps prevent accidental blade exposure. Slip-resistant bi-material grip.



Overall Length	Order Code
165mm	STN-585
	-9085L

martor Megasafe Safety Knife

116001.02
Ergonomic design with a soft grip. Tool-less blade change. Cutting depth 20mm.









Description	Order Code
Knife	MRR-537
No 99.7 Blade Pk 10	-5700E
No 60099 Rounded blade tips Pk 100	-5680M
	-5670H

martor Heavy Duty Safety Knife

SECUPRO 625
Fully automatic blade retraction. Squeeze-grip knife with large cutting depth. High-quality aluminium handle featuring soft grip. Extra safety using a round tip anti-stab blade.
Cutting Depth: 21 mm.
Weight: 151g.



Description	Order Code
Knife	MRR-537
No 99.7 Blade Pk 10	-7550G
No 60099 Rounded blade tips Pk 100	-5680M
	-5670H

		Safety Level 1 Good	Ambidextrous	Aluminium body	Glass fibre reinforced plastic body	Lanyard hole	Bi-material grip	Spare blade storage	Tool-less blade change	Folding body	Sliding body	Order Code
	Kennedy	•	•	•		•		•				KEN-537-0515K
	Kennedy	•	•	•			•	•	•			KEN-537-0790K
	Kennedy	•	•	•			•				•	KEN-537-1120K
	Stanley	•	•		•	•			•	•		STN-585-2462F
	Martor	•	•	•					•			MRR-537-6767Q
	Martor	•	•	•		•			•			MRR-537-7594E
	Martor	•	•		•	•			•			MRR-537-7584H

KENNEDY PROFESSIONAL

Auto Return

Fixed blade. Spring loaded plastic slide mechanism, automatically retracts the blade back into the handle when pressure is released. Accepts heavy duty blades only.



Overall Length	Weight each	Order Code
150mm	165g	KEN-537-0515K

STANLEY

Pocket Folding Safety Knife

Auto retract blade for safety. Takes standard and round nose blades. Instant blade change.



Order Code
STN-585-2462F

martor

Profi40 Safety Knife 119001.02

- Automatic blade retraction
- Tool-less blade change
- Ergonomic
- Extended blade length 40mm
- Cutting depth 36mm
- TÜV-certified
- Measurements (LxWxH): 143 x 17 x 31mm



Description	Order Code
Knife	MRR-537-6767Q
No 7940 Blade Pk 10	-6768R

Auto Retractable Quick Release Safety Knife

Designed for comfort and ease of use, this knife has auto retractable blade and bi-material comfort grip. It also features quick blade release and easy release blade storage. Comes complete with 4 blades.



Product Number	Order Code
SX660	KEN-537-0790K

Quick Change Utility Knife

An innovative sliding blade holder with durable soft touch composite casing. Quick and easy to change blade with no tools needed. One handed operation.



Knife extends to allow auto-retractable blade to be used.

Overall Length	Weight each	Order Code
115mm	120g	KEN-537-1120K

Secunorm 500 Safety Knife 50000110.02

- Rounded-tip trapezoid bladed safety knife
- Blade protects your product with its shortened blade
- Ergonomic handle
- Comes with an intuitively operated blade change button
- Automatic blade retraction
- Overall length: 143mm













Overall Length	Order Code
143mm	MRR-537-7594E

Secunorm 380 380001

Automatic blade retraction. Long blade extension with over 7.5 cm of blade. Safer blade change (with magnet). For right and left handers with safety lock. Extremely pliable blade. Use: cutting foam, glass fibre insulation.



Cutting Depth	Order Code
73mm	MRR-537-7584H

		Aluminium body	Lanyard hole	Bi-material handle	Spare blade storage	Tool-less blade change	Folding body	Two knives in one	Scabbard included	Raised thumb grip	Order Code
	Kennedy	•	•	•	•				•		KEN-537-1000K
	Kennedy	•	•	•	•						KEN-537-0800K
	Kennedy	•	•		•						KEN-537-0500K
	Kennedy	•	•		•					•	KEN-537-0510K
	Senator	•	•		•						SEN-537-0500K
	Yamoto	•	•	•	•						YMT-537-4540K
	Irwin	•			•						IRW-565-3010M
	Stanley	•	•		•						STN-585-2439A
	Stanley	•			•	•			•		STN-585-2442D
	Stanley	•		•		•	•				STN-585-2507N
	Kennedy	•				•		•			KEN-537-0810K

KENNEDY Trimming Knives
 QUALITY INDUSTRIAL TOOLING
Retractable Blade Knife with Scabbard
 Trimming knife supplied with heavy duty blade and impact resistant scabbard.



Quick Release Utility Knife
 Classic design which features quick blade release button, comfort grip handle and lanyard hole.



Retractable - Complete with 5 Heavy Duty Blades
 Slimline die cast body designed to fit comfortably in the hand, with high carbon steel blades. Up to five spare blades can be stored in the handle.



Retractable - Complete with 5 Heavy Duty Blades
 Slimline diecast body with contoured grip. High carbon steel blades. Spare blades can be stored in the handle.



SENATOR Retractable Trimming Knife
 QUALITY TOOLING
 Diecast aluminium body with retractable locking blade, built-in hanging hook. Complete with 1 spare blade.



YAMOTO Retractable Trimming Knife
 Turn wheel anti-clockwise to unlock. Turn continuously to disassemble for blade change.



IRWIN Pro-Touch™ Utility Knife
 Aluminium body. Quick change blade mechanism. Stores up to 10 blades.



STANLEY Trimming Knife
 2-10-099 (099E)
 Die Cast Zinc Body. Textured non-slip grip. Supplied with three blades.



STANLEY Titan Trimming Knife
 High strength aluminium alloy body for improved user comfort and control. Overlap nose design prevents blade push through under heavy pressure. Easy

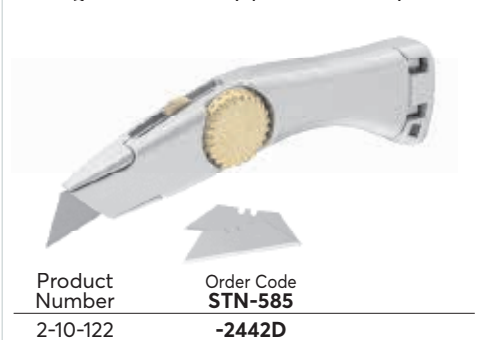

Retractable Folding Knife
 Rubberised thumb pad for comfort and a tool free blade change feature. Retractable blade for added safety. Instant blade change - no tools needed. Internal blade storage. With integrated strapping cutter.



KENNEDY Twin Headed Quick Release Utility Knife
 QUALITY INDUSTRIAL TOOLING
 Two knives in one with an interlocking mechanism which ensures only one blade can be used at a time. Features quick blade release and easy blade change function.

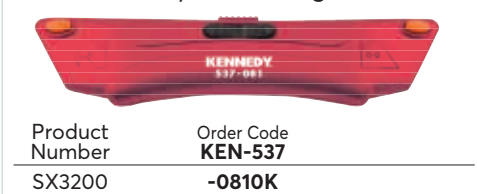

		Aluminium body	Lanyard Hole	Bi-material handle	Spare blade storage	Tool-less blade change	Folding body	Sliding body	Scabbard included	Order Code
	Kennedy	•	•		•	•			•	KEN-537-0480K
	Kennedy	•	•		•					KEN-537-0530K
	Stanley	•	•		•					STN-585-2461R
	Stanley	•	•		•					STN-585-2462S
	Stanley	•			•	•			•	STN-585-2468C
	Yamoto	•	•		•	•				YMT-537-4520K
	Kennedy	•		•		•	•			KEN-537-0640K
	Stanley	•				•		•		STN-585-2505L

KENNEDY QUALITY INDUSTRIAL TOOLING

Hercules Pattern Trimming Knives

Heavy duty fixed blade pattern, with interlocking body to prevent blade pop up during arduous cutting applications. The spring opening mechanism allows rapid replacement of dulled blades without the need for any other tool. Spare blades are stored in body.
Fixed Blade



Impact Resistant Scabbard

The spring opening mechanism allows rapid replacement of dulled blades

Overall Length	Weight each	Order Code
185mm	347g	KEN-537-0480K

Fixed - Complete with 5 Heavy Duty Blades

Die cast body with heavy duty knurled style for extra grip which provides a greater degree of control and comfort.



Overall Length	Weight each	Order Code
135mm	150g	KEN-537-0530K

STANLEY Trimming Knives & Blades

1-10-550 Titan FB - Fixed Blade
Heavy duty knife. Ergonomically designed aluminium alloy body. Tough epoxy coating. Overlap nose design prevents blade push through when under heavy pressure. Easy blade change no screwdriver required. Supplied complete with polypropylene belt scabbard and three blades stored in body.



Product Number	Overall Length	Order Code
1-10-550	175mm	STN-585-2468C

Fixed - Complete with 5 Heavy Duty 2-10-199 (199)

Features blade holder inside the handle for safe storage. The knife come with 3 extra blades. The over lapping nose blade locking system for greater safety during cutting.

- Die Cast Zinc Body
- Textured non-slip grip



Overall Length	Order Code
140mm	STN-585-2461R

Trimming Fixed Blade Utility Knife

- 0-10-299**
- Fixed Blade
 - Cast metal body with blade storage
 - Supplied with 3 spare blades
 - Overall length: 136mm locking system for greater safety during cutting.
 - Die Cast Zinc Body
 - Textured non-slip grip



Overall Length	Order Code
140mm	STN-585-2462S

YAMOTO Wheel Lock Trimming Knife

Fixed Blade
Turn anti-clockwise to unlock. Turn continuously to disassemble for blade change.



Overall Length	Order Code
155mm	YMT-537-4520K

KENNEDY PROFESSIONAL Quick Release Folding Knife

Quick release blade and folds to 9 x 3.5cm to stow using the integral belt clip. Accepts medium, heavy duty and hook blades. With blade guard.



Product Number	Order Code
KQF935	KEN-537-0640K

STANLEY Quickslide Utility Knife

Durable all-metal, die-cast zinc construction. Swivels open for 'no-tools' blade changes (Compatible with all standard blades). With sliding blade holder for one-handed operation. One-piece belt clip.

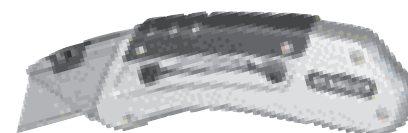

Product Number	Overall Length	Order Code
5-10-810	145mm	STN-585-2505L

Utility Knives - Replacement Blades

STANLEY**Knife Blades**

- 911 Normal duty blade.
921 Heavy duty blade.
987 Snub-nose safety blade.
*Dispenser pack.

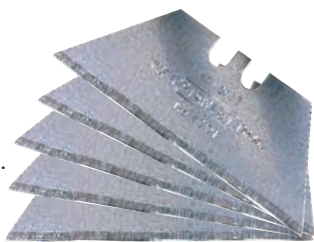

Product Number	Pack Quantity	Order Code
0-11-911	5	-2560H
1-11-911	100	-2562K
2-11-921	10	-2573A
0-11-921	5	-2570P
3-11-921	10*	-2573S
1-11-921	100	-2572R
4-11-987	10	-2629A

1996

Sharpened hooks with point.



Product Number	Pack Quantity	Order Code
0-11-983	5	-2620B
1-11-983	100	-2622D

FatMax™ Blades

75% longer life, 20% stronger, 35% sharper, snap resistant to 35kg.



Product Number	Pack Quantity	Order Code
5-11-700	5	-2542M
6-11-700	10	-2543N
8-11-700	100	-2544P

FatMax® Carbide™ Blade 8-11-800

- 10% longer life, 20% stronger, snap resistant to 35kg.
- Overall length: 62mm
 - Width: 19mm
 - Pack qty: 5



Overall Length	Pack Quantity	Order Code
62	5	-2556W

5192B Knife Blades Concave 0-11-952

- Blade type: Concave
- Dimensions (LxW): 60 x 0.7mm
- Pack Quantity: 5



Pack Quantity	Order Code
5	-2600G

YAMOTO**Trimming Knife Blades**

Heavy-duty. For use on carpets and vinyl etc.

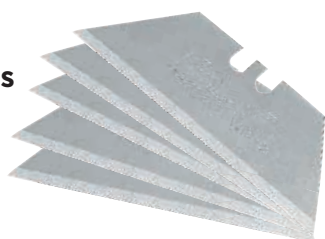

Pack Quantity	Order Code
5	-4310K
10	-4320K
100	-4330K

IRWIN**Bi-Metal Blades**

Combines spring backing steel with an electron beam welded high speed steel edge. Spring backing steel's flexibility reducing the chance of shattering for operator safety. Heat treated HSS cutting edge's long blade life and edge sharpness. Lasts up to three times longer than carbon steel blades. Bulk packs 10, 50 and 100 are supplied in dispenser boxes.



Product Number	Pack Quantity	Order Code
10504241	10	-3060S
10504243	100	-3080V

Snub Nose Blades

Reduce risk of accidents.



Product Number	Pack Qty	Order Code
10505823	5	-4830B

KENNEDY
QUALITY INDUSTRIAL TOOLING**Knife Blades**

Kennedy Industrial quality knife blades have a superior edge hardening for longer tool life and sharper edge.

Medium Duty

For use on paper, card and leather.



Pack Quantity	Weight Per Pk	Order Code
5	30g	-2540K
100	250g	-2550K

Heavy Duty

For use on carpets and vinyl.



Pack Quantity	Weight Per Pk	Order Code
5	30g	-2560K
10	55g	-2500K
100	250g	-2570K

Hook Type

With point, suitable for penetrating and cutting sheet materials.

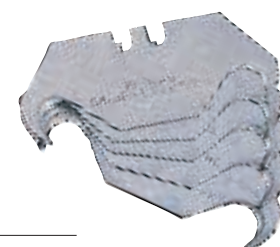

Pack Quantity	Weight Per Pk	Order Code
5	30g	-2580K
100	250g	-2590K

Order online at cromwell.co.uk or call

North **0800 028 3602** | Central **0800 028 3191** | South **0800 028 3189**

1023

		18mm Wide Blade	8 Segment Blade	9mm Wide Blade	7 Segment Blade	13 Segment Blade	Micro knife	Disposable	Ultra Slim	Auto Load Blades	Blade Lock	Soft Grip	Blade Snapper	Plastic Body	Metal Body	Wheel Lock	Order Code
	Kennedy	•	•							•		•		•			KEN-537-0740K
	Kennedy	•	•											•			KEN-537-0350K
	Kennedy	•	•											•			KEN-537-0370K
	Senator	•	•											•			SEN-537-0330K
	Senator	•	•								•			•			SEN-537-0410K
	Stanley	•	•											•			STN-585-2451F
	Stanley	•	•												•	•	STN-585-2418P
	Irwin	•	•									•			•		IRW-565-6106K
	Kennedy			•	•					•		•		•			KEN-537-0720K
	Kennedy			•	•									•			KEN-537-0310K
	Kennedy			•	•									•			KEN-537-0290K
	Kennedy			•	•		•	•						•			KEN-537-0200K
	Senator			•	•						•			•			SEN-537-0430K
	Yamoto			•	•										•	•	YMT-537-4650K
	Stanley			•	•									•			STN-585-2445B
	Stanley			•	•									•		•	STN-585-2435Y
	Kennedy			•	•				•						•		KEN-537-0250K

KENNEDY PROFESSIONAL

Autoload & Lock Knife

ABS plastic with rubber coating for extra grip. Steel blade slides prevent blade slippage or case splitting and give the knife a smooth action. Auto-load feature. As used blade is ejected, a new blade is automatically loaded into place.



Overall Length	Blade Segments	Weight each	Order Code
170mm	8	165g	KEN-537-0740K

Snap-off Blade Retractable Knife

High strength ABS plastic construction with slider lock.

Standard: 160mm. 18 x 100mm, 8 segment blade.



Overall Length	Weight each	Order Code
160mm	86g	KEN-537-0350K

Snap-off Blade Retractable Knife

High strength ABS plastic construction with slider lock.

Standard: 18 x 100mm. 8 segment blade.



Overall Length	Weight each	Order Code
160mm	38g	KEN-537-0370K

SENATOR QUALITY TOOLING

Utility Knives

A range of Snap-off blade knives with contoured moulded grips and steel slides. Blade locking mechanism in the thumb slide. Replacement blades available on request.

Snap-off Blade
8 segment, 18mm heavy duty.



Overall Length	Weight each	Order Code
130mm	60g	SEN-537-0330K

Snap-off Blade Knife
8 segment, 18mm economy.



Overall Length	Weight each	Order Code
130mm	60g	SEN-537-0410K

STANLEY Snap-off Knife

SM - ABS Plastic Body Retractable
Has blade snapping slot and space for spare blade storage. Multi-position slide button.

0-10-151
18 x 122mm, 8 segment blade.



Overall Length	Weight each	Order Code
160mm	43g	STN-585 -2451F

Retractable Trimming Knife

Interlock nose system. Easy blade change. Twist and turn release mechanism. Nickel alloy body.



Overall Length	Order Code
165mm	STN-585 -2418P

IRWIN Pro-Touch™ Auto-Load Snap-off Blade Knife

A lightweight and hard wearing aluminium body. Soft touch grip for extra comfort. Blades automatically loaded as used blade is ejected. Three blades included.



Product Number	Weight each	Order Code
10507106	180g	IRW-565 -6106K

KENNEDY Snap-off Knife Blades

Kennedy Industrial quality knife blades have a superior edge hardening for longer tool life and sharper edge. Best value with longer working between blade changes.



Overall Length	Pack Quantity	Weight each	Order Code
18 x 100	10 50	72g	KEN-537 -2050K -2070K

STANLEY Snap-off Knife Blades

1-11-301 = 8 segment.



Product Number	Pack Quantity	Order Code
0-11-301	10	STN-585 -2533S
1-11-301	100	STN-585 -2534T

FatMax™ Blades

Best ever Stanley Snap-off Blade with patented induction hardened edge. **Pack quantity: 5.**



Product Number	Blade Size	Order Code
5-11-718	18mm	STN-585 -2548W

IRWIN Snap-Off Bi-Metal Blue Blades

Revolutionary blade that lasts 3x longer.

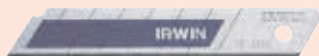

Product Number	Blade Size	Pack Quantity	Order Code
10507103	18mm	8	IRW-565 -6103G

YAMOTO Snap Off Knife Blades

Best value with longer working between blade changes.



Number of Segments	Pack Qty	Order Code
8	100	YMT-537 -1020K

KENNEDY Autoload & Lock Knife

ABS plastic with rubber coating for extra grip. **Unique spring loaded automatic blade replacement.**



Overall Length	Blade Segments	Weight each	Order Code
140mm	13	65g	KEN-537 -0720K

Snap-off Blade Retractable Knives

High strength ABS plastic construction with slider lock.

Mini: 140mm. 9 x 91mm, 13 segment blade.



Overall Length	Weight each	Order Code
140mm	32g	KEN-537 -0310K

Mini: 9 x 91mm, 13 segment blade.



Overall Length	Weight each	Order Code
130mm	21g	KEN-537 -0290K

Retractable Micro Pocket Knife

Blade snapper and locking mechanism. 7 segment 9mm wide blade.



Overall Length	Weight each	Order Code
100mm	6g	KEN-537 -0200K

SENATOR Utility Knife

Contoured moulded grip and steel slide. Blade locking mechanism in the thumb slide.

Snap-off Blade
13 segment, 9mm standard.



Overall Length	Weight each	Order Code
130mm	60g	SEN-537 -0430K

YAMOTO Wheel Lock Knife

Turn anti-clockwise to unlock. With snap-off segmented blades.



Number of Segments	Order Code
13	YMT-537 -4650K

STANLEY Snap-off Knives

SM - ABS Plastic Body Retractable
Has blade snapping slot and space for spare blade storage. Multi-position slide button.

0-10-150
9 x 85mm, 13 segment blade.



Overall Length	Weight each	Order Code
130mm	15g	STN-585 -2445B

0-10-095
9 x 85mm, 13 segment blade.



Overall Length	Weight each	Order Code
130mm	60g	STN-585 -2435Y

KENNEDY Ultra Slim

Precision knife. Black coated. 13 segment, blade 9 x 91mm.



Overall Length	Weight each	Order Code
130mm	20g	KEN-537 -0250K

KENNEDY Snap-off Knife Blades

Kennedy Industrial quality knife blades have a superior edge hardening for longer tool life and sharper edge. Best value with longer working between blade changes and with easy, safe segment-snap to renew leading edge.

9 x 91mm - 13 segments



Overall Length	Pack Quantity	Weight each	Order Code
9 x 91	10 50	23g	KEN-537 -2110K -2140K

YAMOTO Snap Off Knife Blades

Best value with longer working between blade changes and with easy, safe segment-snap to renew leading edge.



Number of Segments	Pack Quantity	Order Code
13	10 100	YMT-537 -1080K -1090K

STANLEY Snap-off Knife Blades

1-11-300 = 13 segment.



Product Number	Pack Quantity	Order Code
1-11-300	100	STN-585 -2530P

Order online at cromwell.co.uk or call

North **0800 028 3602** | Central **0800 028 3191** | South **0800 028 3189**

1025

KENNEDY
QUALITY INDUSTRIAL TOOLING

Disposable Knife

Fixed ground steel blade. Non-slip finger/thumb grip. Ideal for industrial use, modelling and craft work. Plastic safety cap with pocket clip.



Overall Length	Order Code
155mm	KEN-537 -0070K

Throwaway Knives

0-10-601

• Yellow plastic handle with a permanently attached 5901 blade, with guard
• Length: 140mm



Pack Quantity	Order Code
5	STN-585 -2481K

0-10-590 Slim Knife Fixed

Die cast body with interlock blade securing, prevents blade push through when under pressure. Supplied complete with five spare blades stored in the handle.



Overall Length	Weight each	Order Code
122mm	65g	STN-585 -2470D

Carbon Steel Non-Sterile Blades

No.10A

Non-sterile, for use with No.3 type handle.



Style	Pack Quantity	Order Code
10A	100	KEN-537 -7015K

No.11

Non-sterile, for use with No.3 type handle.



Style	Pack Quantity	Order Code
11	100	KEN-537 -7025K

No.15

Non-sterile, for use with No.3 type handle.



Style	Pack Quantity	Order Code
15	100	KEN-537 -7035K

YAMOTO Folding Pocket Knife

Zinc die cast body. For all general-purpose cutting and trimming applications.

Body length: 100mm.

Open length: 135mm. Spring blade mechanism automatically locks the blade in open or closed position. Two blades can be stored in the body. Can be fitted to key ring.



Overall Length	Order Code
135mm	YMT-537 -1500K

Folding Pocket Knife Blades

Spare Knife Blades

Pack of five blades to suit (YMT -537-1500K) folding knife.



Pack Quantity	Order Code
5	YMT-537 -1520K
50	YMT-537 -1530K

STANLEY Craft Knife

0-10-598 Pocket Folding

Die cast body finished with black epoxy. Spring loaded blade mechanism automatically locks the blade in the open or closed position. A spare blade can be stored in the handle. Supplied complete with two blades.

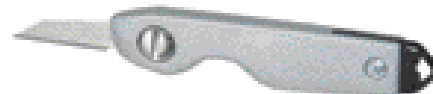

Overall Length	Order Code
110mm	STN-585 -2478H

Craft Knife Blades

5901

Straight, general-purpose light duty.



Product Number	Pack Qty	Order Code
0-11-221	3	STN-585 -2519J
1-11-221	50	STN-585 -2521L

KENNEDY Non-Sterile Handles

No.3 & 4 Style

Non-sterile nickel alloy handle with textured body. For precision use in modelling and craft work. Dulled blades can be changed quickly and easily.



Handle Type	Overall Length	Weight each	Order Code
No.3	123mm	27g	KEN-537 -7230K
No.4	135mm	27g	KEN-537 -7240K

No.21

Non-sterile, for use with No.4 type handle.



Style	Pack Quantity	Order Code
21	100	KEN-537 -7045K

No.22

Non-sterile, for use with No.4 type handle.



Style	Pack Quantity	Order Code
22	100	KEN-537 -7055K

No.23

Non-sterile, for use with No.4 type handle.



Style	Pack Quantity	Order Code
23	100	KEN-537 -7065K



Each blade is packaged in safety foil for easier handling.

No.24

Non-sterile, for use with No.4 type handle.



Style	Pack Quantity	Order Code
24	100	KEN-537 -7075K

No.26

Non-sterile, for use with No.4 type handle.



Style	Pack Quantity	Order Code
26	100	KEN-537 -7085K

Precision Knives

Suitable for modellers art and craft workers and wood carvers. Ideal for making point of sale samples where precision cutting is required. Available in three styles:

TK1 - Light duty: lightweight, small diameter aluminium handle suitable for cutting on paper, soft and lightweight materials or wood.

TK2 - Medium duty: lightweight, large diameter aluminium handle suitable for cutting heavy paper and medium density materials.

TK5 - Heavy duty: fluted, ABS plastic handle suitable for working with hardwood, plastic and other difficult to cut materials.

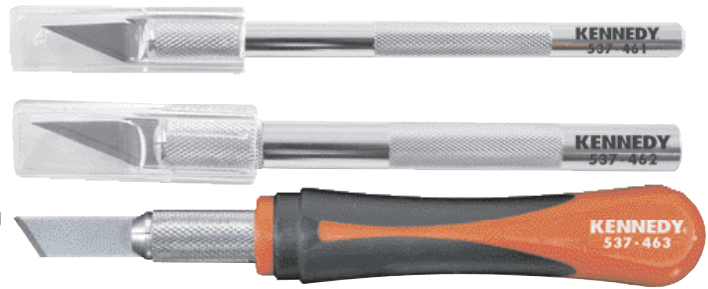

Product Number	Duty	Weight each	Order Code
TK1	Light	28g	-4610K
TK2	Medium	47g	-4620K
TK5	Heavy	47g	-4630K

KENNEDY Precision Knife Set
QUALITY INDUSTRIAL TOOLING

Multi-purpose knife set, ideal for modelling, craft work and industrial use. Covers a wide range of applications including cutting, chiselling, stencilling and scoring. All holders have a positive guide locator to provide extra safety when changing blades.

Contents:

- 1x light duty holder.
- 1x medium duty holder.
- 1x fluted ABS holder.
- 1x general cutting and trimming blade.
- 1x general cutting and slicing blade.
- 3x detail cutting and stripping blade.
- 1x medium/heavy duty cutting blade.
- 1x stencilling and scoring blade.
- 1x precision wood chiselling blade.
- 1x deep cross and smooth wood chiselling blade.
- 2x chiselling and trimming blade.
- 1x heavy duty cutting blade.
- 1x close corner cutting blade.



Number Of Pieces	Weight each	Order Code
16	235g	KEN-537 -5100K

Kennedy Precision Blades
General Cutting & Trimming

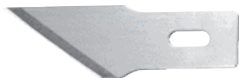

Pack Quantity	Weight each	Order Code
10	9g	KEN-537 -7520K

General Cutting & Slicing



Pack Quantity	Weight each	Order Code
10	9g	KEN-537 -7280K

Detail Cutting & Stripping

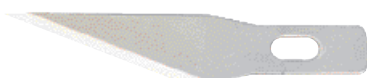

Pack Quantity	Weight each	Order Code
5	8g	KEN-537 -7310K

Stencilling & Scoring



Pack Quantity	Weight each	Order Code
5	9g	KEN-537 -7350K

Precision Wood Chiselling



Pack Quantity	Weight each	Order Code
5	12g	KEN-537 -7550K

Deep Cross & Wood Chiselling



Pack Quantity	Weight each	Order Code
5	9g	KEN-537 -7400K

Chiselling & Trimming



Pack Quantity	Weight each	Order Code
10	10g	KEN-537 -7410K

Heavy Duty Cutting



Pack Quantity	Weight each	Order Code
5	9g	KEN-537 -7420K

Close Corner Cutting



Pack Quantity	Weight each	Order Code
10	9g	KEN-537 -7480K

Medium/Heavy Duty Cutting



Pack Quantity	Weight each	Order Code
10	10g	KEN-537 -7470K

Ceramic technology

- Finger friendly
- Lasts up to 10x longer than steel
- Fewer blade changes
- Less downtime
- Lower costs
- A safer working environment



sliceSM Scalpel

Fixed blade with a slim flat handle.



Description	Order Code
Knife	SLC-537
4 spare blades	-1070Y
	-1055P

Craft Knife

Fixed blade with a round textured grip handle.



Description	Order Code
Knife	SLC-537
4 spare blades	-1066D
	-1055P

Replacement Blades



Description	Order Code
4 Spare blades	SLC-537
	-1055P

SENATOR QUALITY TOOLING 11-Blade 2 1/2" Spear Point Pocket Knife

Traditional style impact resistant plastic handle, with stainless steel blades.

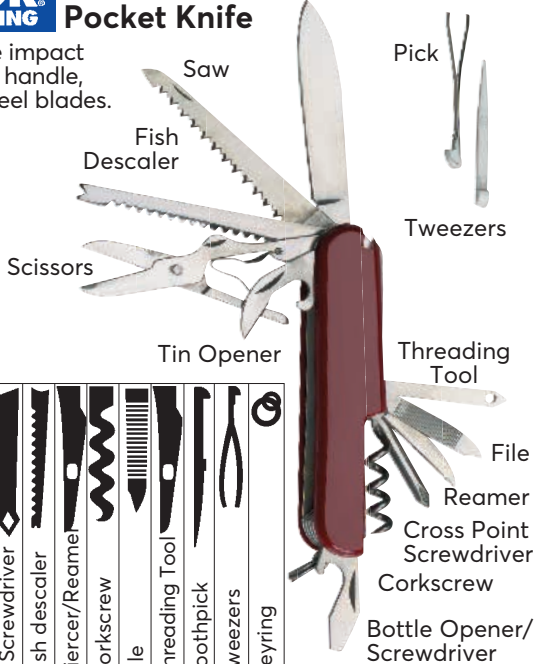

Blades	Tools
2 1/2" Spear Point	Keyring
Saw	Tweezers
Scissors	Threading Tool
Screwdriver & Bottle Opener	File
Tin Opener	Reamer
Screwdriver	Cross Point Screwdriver
Fish scaler	Corkscrew
Piercer/Reamer	Bottle Opener/Screwdriver
Corkscrew	
File	
Threading Tool	
Toothpick	
Tweezers	
Keyring	

Order Code	SEN-537
	-1100K

SWISS+TECH Pocket Knife

4 Blade Pocket Knife
All stainless steel construction. Satin finish handle with 3 rubber grip strips for added grip.



Blade Length	Weight each	Order Code
2"	95g	SWT-537
		-1040K

SENATOR QUALITY TOOLING Locking Knife

With rosewood handle. Stainless steel blade and brass fittings.



Blade Length	Weight each	Order Code
3"	160g	SEN-537
4"	170g	-1200K
		-1300K

2-Blade Pocket Knife

With traditional style rosewood handle. Stainless steel blade and brass fittings.



Blade Length	Weight each	Order Code
2"	95g	SEN-537
		-1000K

KENNEDY Hacksaw Frames
QUALITY INDUSTRIAL TOOLING

150mm (6") BLADE

Pro-Grip Junior

Rigid steel frame. Contoured die cast handle with knuckle guard. Thumb screw blade tensioner. Complete with blade



Overall Length	Weight per 12	Order Code
235mm	2.50kg	KEN-538 -0550K

ECLIPSE Piercing Saw
QUALITY INDUSTRIAL TOOLING

125mm (47/8") BLADE

Fixed steel frame with a wooden handle. Used for fine metalwork by jewellers, clockmakers and all skilled craftsmen.



Product Number	Length (mm)	Order Code
PS51	292	ECL-553 -0540G

Spare Blades to suit above
Blade length: 125mm.

Product Number	TPI	Order Code	
PS32	32	ECL-553	00
PS44	44	-0542J	
PS52	52	-0543K	
PS60	60	-0545M	
PS80	80	-0546N	
		-0547P	

Fretsaw

70-FS1R

Fret saw for fine cutting work in thin materials such as wood, bone, plastics, etc - ideal for model makers.

Overall Length: 270mm.



Product Number	Height (mm)	Order Code
70-FS1R	300	ECL-553 -0742B

Spare Blade to suit above

Product Number	TPI	Order Code	
FS22	22	ECL-040	00
FS18	18	-0960K	
FS16	16	-0970K	
		-0980K	

ECLIPSE Coping Saw
QUALITY INDUSTRIAL TOOLING

The blade can be rotated at any angle to that it for coping and materials.

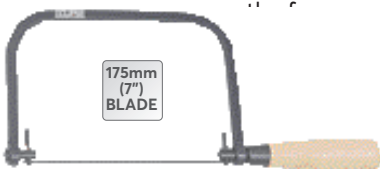

Product Number	Length (mm)	Order Code
70-CP1R	315	ECL-553 -0740A

Spare Blade to suit above
Blade length: 175mm.

Product Number	TPI	Order Code	
71-CP7R	14	ECL-553	0
		-0761L	

YAMOTO Junior Hacksaw
QUALITY INDUSTRIAL TOOLING

150mm (6") BLADE

Features an aluminium handle and tension adjustment screw. Supplied with a general purpose blade.



Order Code
YMT-538 -0300K

Quick Release Junior Hacksaw

Featuring a quick release mechanism for fast and easy blade change, this hacksaw combines a robust design with a moulded handle. Supplied with general purpose blade.

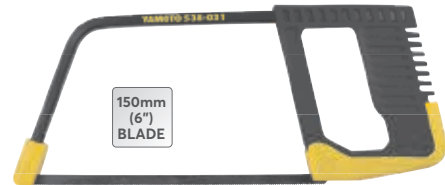

Order Code
YMT-538 -0310K

SENATOR Junior Hacksaw
QUALITY TOOLING

150mm (6") BLADE

Comprising a robust steel frame with finger guard, this lightweight hacksaw comes supplied with a general purpose blade



Order Code
SEN-538 -0300K

KENNEDY Pad Saw
QUALITY INDUSTRIAL TOOLING

145mm BLADE

Heavy duty foam grip. Accepts 1/2" deep hacksaw blades. Suitable for use in areas of awkward access.



Overall Length	Weight each	Order Code
275mm	130g	KEN-538 -1000K

Coping Saw

For cutting and shaping in wood.



Overall Length	Weight each	Order Code
290mm	200g	KEN-538 -2100K

Spare Blades to suit above

Length (mm)	TPI	Pk Qty	Order Code
150 (6")	14	10	KEN-040 -1020K

KENNEDY Hacksaw Frames
QUALITY INDUSTRIAL TOOLING

150mm (6") BLADE

Beaver Style

High impact resistant pistol grip. Steel oval section frame for strength and rigidity. Thumb screw blade tensioning. Supplied complete with 18tpi metal cutting blade.



Overall Length	Weight per 12	Order Code
275mm	1.80kg	KEN-538 -0630K

Low Profile Junior Hacksaw

150mm (6") BLADE

Manufactured from rigid and lightweight aluminium with hi-strength I-beam frame. Moulded 'soft touch' cushion grip. Supplied with blade.



Overall Length	Weight per 12	Order Code
250mm	2.70kg	KEN-538 -0500K

Standard Junior Pattern

150mm (6") BLADE

Epoxy coated spring steel frame, keeps the blade tensioned correctly at all times. Suitable for smaller applications, where the workpiece cannot be held firmly. Complete with 32tpi blade.



Overall Length	Weight per 50	Order Code
260mm	6.40kg	KEN-538 -0600K

Spare Blade

Type	Length (mm)	TPI	Order Code	Price
Metal	150	32	KEN-040	/10
Wood	150	14	-0620K	/1

Mini Hand Saw - Comfort Grip

Plastic pistol grip with slip resistant grooves, spring steel frame. Complete with blade.



Overall Length	Weight per 12	Order Code
216mm	1.20kg	KEN-538 -0620K

Tile Saw

Abrasive coated blade suitable for cutting intricate shapes, to allow flush fitting of tiles. Supplied with blade.



Overall Length	Weight each	Order Code
200mm	210g	KEN-538 -3600K

Spare Blade to suit above

Length (mm)	Weight each	Order Code
150	4g	KEN-040 -1400K

Order online at cromwell.co.uk or call

North 0800 028 3602 | Central 0800 028 3191 | South 0800 028 3189



Professional 'Plus' Hacksaw

Heavy duty steel frame with front grip and 'D' style handle with grooved slip resistant rubber inlay for positive control and comfort. Wing nut and lever blade tensioning. The blade can be set at 45° to the frame to allow flush cutting. Supplied with blade.



300mm (12") BLADE

Overall Length	Weight per 5	Order Code
400mm	3.80kg	KEN-538 -2350K

Adjustable Hacksaw

Die-cast 'D' style handle for user comfort and control. Epoxy coated tubular steel frame for strength and rigidity. The blade can be set at 90° to the frame to allow cutting in areas with restricted access. Wing nut blade tensioning. Accepts 250mm (10") and 300mm (12") blades. Supplied with blade.

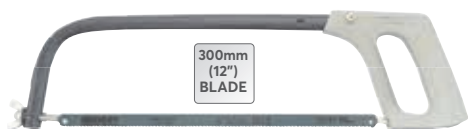

300mm (12") BLADE

Overall Length	Weight per 5	Order Code
475mm	3.20kg	KEN-538 -0650K

2-Piece Hacksaw Set

Beaver style 150mm (6") junior hacksaw and 250/300mm (10"/12") adjustable hacksaw with wing nut tensioner.



165mm (6 1/2") BLADE

2 PIECES

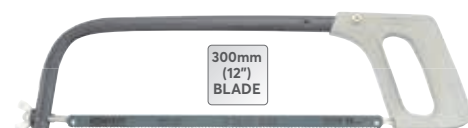

300mm (12") BLADE

Weight each	Order Code
850g	KEN-538 -3000K

Hacksaw Frame & Blade Set

250/300mm (10"/12") hacksaw frame with 10x 12" x 1/2" x 18tpi HSS blades.



300mm (12") BLADE

2 PIECES



Weight each	Order Code
850g	KEN-538 -3050K



Hi Tension Hacksaw

HT50

Lever in handle tensions 12" blade to 50,000psi. Blade won't twist or bind. Spare blades store inside back. Cast aluminium and steel frame.

Depth of cut: 4"



300mm (12") BLADE

Overall Length	Order Code
300mm	LNX-538 -5542B



Multi-Position Hacksaw

603F

Blade rotation through 360° without removal. Automatic blade tensioning for easy blade fitting. Machined and shouldered pins for secure blade retention. 45° cutting angle increments. Aluminium construction. Ergonomic handle.

Overall dimensions: 429 x 137mm.

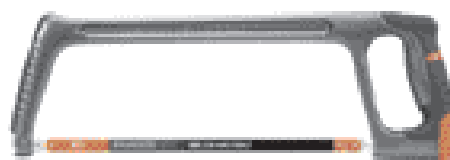

Product Number	Order Code
603F	FAC-538 -6032A

YAMOTO Comfort Grip Hacksaw

Combining robustness with comfort, this 12" (300mm) hacksaw features contoured handle, 45° and 90° blade positioning and tension adjustment screw. It comes supplied with a general purpose blade.

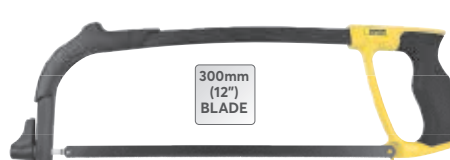

300mm (12") BLADE

Order Code
YMT-538 -0430K

Lightweight Hacksaw Frame

Strong and rigid construction frame with die-cast aluminium handle. Wing nut and lever blade tensioning allow easy blade replacement. The blade can be set at 90° for straight cuts and at 35° to the frame for flush cutting. Supplied with blade.

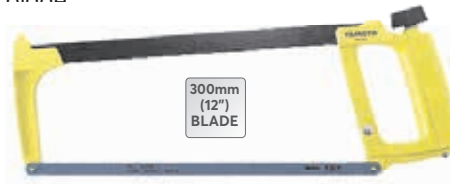

300mm (12") BLADE

Overall Length	Weight per 5	Order Code
400mm	3.80kg	YMT-538 -2250K

Hacksaw Frame

Lightweight body with wing nut blade tensioner. Supplied with blade. Suitable for light duty and workshop use.

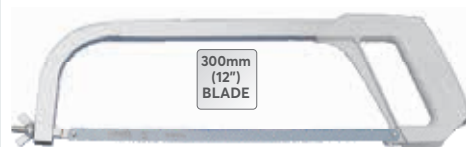

300mm (12") BLADE

Overall Length	Weight per 6	Order Code
440mm	3.10kg	SEN-538 -0010K

10 - 12" Adjustable Hacksaw

Tension adjustment screw can be adjusted to hold a 250mm (10") or 300mm (12") blade. It comes with a general purpose blade.



300mm (12") BLADE

Overall Length	Weight each	Order Code
440mm	3.10kg	SEN-538 -0390K

ECLIPSE Adjustable Hacksaw

Traditional hacksaw with die-cast 'D' style handle and solid frame. The blade can be adjusted to fit at right angles to the frame.



300mm (12") BLADE

Product Number	Weight each	Order Code
70-20TR	320g	ECL-553 -0748E

BAHCO Hacksaw Frames

225-S has a rectangular back section and blade storage. Centred blade for correct balance and spring tensioned loading mechanism for quick blade changes. Has an alternative 55° mounting for flush cutting and is supplied with a bi-metal blade.

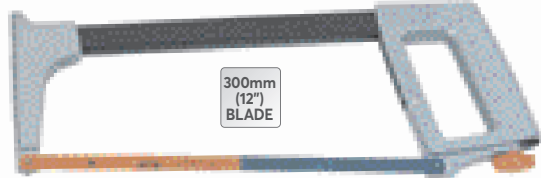

Product Number	Weight per 5	Order Code
225-PLUS	2.35kg	BAH-538 -2030P

IRWIN 12" Hacksaw

I-125
Heavy duty, ergonomic metal frame for higher blade tension preventing the blade being released when dropped. Metal tensioning mechanism. Soft touch handles ensure a comfortable sawing grip and prevents slippage. Blade storage. 90° - 55° blade mounting for sawing large objects. Jab-Saw for sawing in confined spaces.

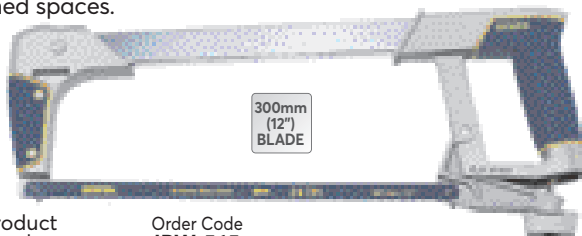

Product Number	Order Code
I-125	IRW-565 -3310L

Spare Blades

Blade Length mm	Blade Length in.	TPI	Order Code
30	12	18	IRW-040 -1218H
30	12	24	-1224H
30	12	32	-1232H

STANLEY FatMax® 5-in-1 Hacksaw

This FatMax® hacksaw from Stanley® is a versatile piece of kit in that it can be converted to 45° and 90° standard blade positions, 2x pad saw positions, 1x 45° access saw. Other features include in-frame spare blade storage. In the standard blade position the lightweight frame holds the blade securely at 100kg of tension.



Product Number	Overall Length	Order Code
0-20-108	400mm	STN-538 -2010J

Saw Frames

KENNEDY Low Profile Hacksaw

Manufactured from rigid and lightweight aluminium with hi-strength I-beam frame. Moulded 'soft touch' cushion grip. Features wing nut blade tensioning and 0° and 45° blade settings. Supplied with blade.

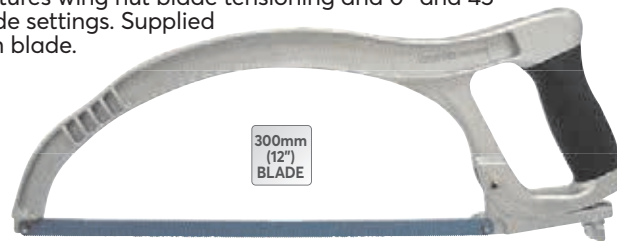

Overall Length	Weight per 5	Order Code
410mm	2.75kg	KEN-538 -0800K

Offset Hacksaw Frame

For use in av for flush cut' aluminium I plated, steel Supplied w



Reaches the parts other frames cannot reach...

Overall Length	Weight per 5	Order Code
300mm	2.10kg	KEN-538 -0700K

KENNEDY Flexible Back Bi-metal Hacksaw Blades

The perfect combination of shatter resistant spring steel, used as the backing material, and tough, wear-resistant HSS teeth - Electron-beam welded together. Ideal for interrupted cuts in cramped places or where the blade is subject to stress caused by twisting or bending. Provides optimum tooth strength/life and reduced breakage and fracture when compared to traditional all-hard blades. Made to **BS 1919 : Part 1: 1993**.

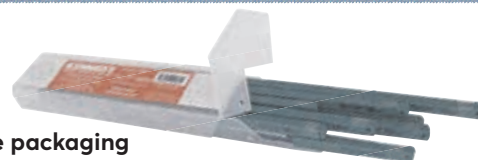

Improved re-usable packaging

Length	Width	Thickness	TPI	Weight per 100	Order Code
12"	1/2"	.025	18T	1.70kg	KEN-040 -2630K

TPI Selection Guide

Group	Materials	Brinell Hardness HB	Rockwell Hardness HRC	Tensile Strength N/mm2	Number of Teeth per Inch Section thickness or diameter		
					Below 2mm	2 - 5 mm	Above 5mm
1.1	Mild steel	<200	-	<700	32	24	18
1.4 to 1.5	Alloy steel & tool steel low to medium	<260	<26	<850	32	24	18 - 24
1.6	High alloy steel	>340	>36	>1200	32	24	24
2.1	Stainless steels	<290	<30	<1000	32	24	28
3.1	Grey cast iron	<300	-	-	24 - 32	18 - 24	18
6.1	Asbestos and copper	-	-	<500	24 - 32	18 - 24	18
6.3	Brass and bronze	-	-	<500	24 - 32	18 - 24	18
7.1	Aluminium	-	-	<500	24 - 32	18 - 24	18
8.1	Hard plastic	-	-	-	24 - 32	18 - 24	18

Order online at cromwell.co.uk or call

North **0800 028 3602** | Central **0800 028 3191** | South **0800 028 3189**

1031



Lightweight Pressed Steel G-Clamps

Welded steel frame with chrome-plated steel screw, handle and swivel shoes. Suitable for light duty applications.



Capacity (mm)	Throat Depth	Weight each	Order Code KEN-539
Standard			
25	27	80g	-1970K
100	48	600g	-2000K
Deep			
63	66	360g	-2010K

Medium Duty G-Clamps

Engineer's clamps with cast anti-twist ribbed frame. For tradesmen, light engineering, woodworker's etc.



Capacity (mm)	Throat Depth	Weight each	Order Code KEN-539
75	40mm	0.75kg	-2730K
100	52mm	1.40kg	-2740K
150	82mm	2.00kg	-2760K

Heavy Duty G-Clamps

Manufactured from drop forged ribbed anti-twist frame steel suited to fabrication and other heavy applications, etc.



Capacity (mm)	Throat Depth	Weight each	Order Code KEN-539
50	33mm	0.35kg	-2020K
75	40mm	0.75kg	-2030K
100	52mm	1.40kg	-2040K
150	82mm	2.00kg	-2060K
200	100mm	3.00kg	-2080K
250	123mm	5.10kg	-2100K
300	127mm	7.60kg	-2120K



Group **405**

Extra Heavy Duty G-Clamps

Manufactured from drop forged steel ribbed anti-twist frame suited to fabrication and welding applications, etc.



Capacity (mm)	Throat Depth	Weight each	Order Code KEN-539
50	32mm	0.45kg	-2220K
75	43mm	0.70kg	-2230K
100	52mm	1.40kg	-2240K
150	72mm	1.90kg	-2260K
200	110mm	4.50kg	-2280K
250	123mm	6.00kg	-2300K
300	130mm	9.00kg	-2320K

Extra Heavy Duty G-Clamps - Copper Plate Screw

Manufactured from drop forged ribbed anti-twist frame steel suited to fabrication and welding applications, etc. Resistant to rusting and weld spatter.



Capacity (mm)	Throat Depth	Weight each	Order Code KEN-539
50	40mm	0.60kg	-2420K
75	50mm	0.70kg	-2430K
100	65mm	1.30kg	-2440K
150	90mm	3.00kg	-2460K
200	110mm	4.50kg	-2480K
250	130mm	5.90kg	-2500K
300	150mm	9.10kg	-2520K

Heavy Duty Deep Throat Clamps

Special clamp manufactured from drop forged steel, with extra throat depth for clamping workpieces further in from the edges, allowing a greater range of applications.



Capacity (mm)	Throat Depth	Weight each	Order Code KEN-539
50	60mm	460g	-2620K
75	80mm	955g	-2630K
100	115mm	2195g	-2640K

Spare Shoes for Heavy, Medium Duty & Deep Throat G-Clamps

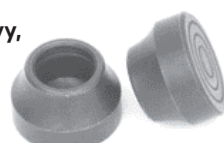

Shoe to fit (mm)	Weight each	Order Code KEN-567
50	10g	-5020K
75	15g	-5030K
100	30g	-5040K
150	40g	-5060K



Light Duty Cast G-Clamps

Light duty cast steel. Suitable for tradesmen, engineer's, woodworker's etc.

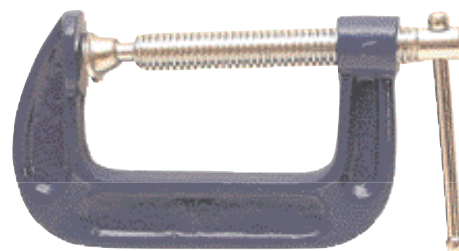

Capacity	Weight each	Order Code SEN-539
50mm	195g	-1020K
100mm	675g	-1040K
150mm	1340g	-1060K

IRWIN Record 119 Slim Section Clamps

Ideal where space is limited. Manufactured from drop forged steel.



Product Number	Capacity (mm)	Weight each	Order Code REC-565
119/2	50	200g	-8460A
119/3	75	500g	-8461B
119/4	100	700g	-8461C
119/6	150	1200g	-8461K

120 General-Purpose Clamps

General-purpose suitable for both wood and metalworking applications. Manufactured from cast SG ductile iron, for strength and rigidity.



Product Number	Capacity (mm)	Weight each	Order Code REC-565
120/3	75	0.60kg	-8462A
120/4	100	0.70kg	-8462C
120/6	150	1.10kg	-8464E
120/8	200	1.70kg	-8465F

Clamps

SENATOR QUALITY TOOLING One-Handed Speed Clamp

Manufactured from pressed steel for strength and durability. Trigger adjustment based on the sealant cartridge applicator gun. Quick release thumb lever. High strength hexagonal steel thrust rod with swivel shoe for clamping non parallel surfaces. High strength plastic contact pads.

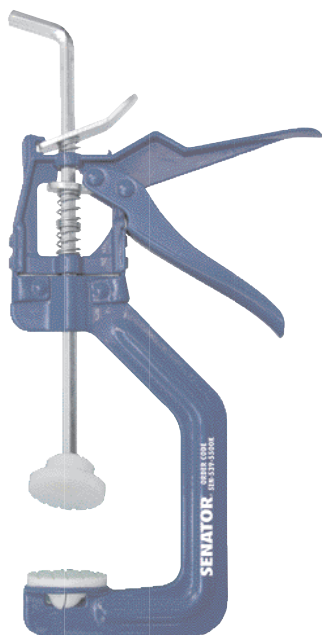

Capacity (mm)	Throat Depth (mm)	Order Code SEN-539
100	56	-5500K

KENNEDY QUALITY INDUSTRIAL TOOLING T-Handle Clamps

General-purpose. Manufactured from medium heat treated carbon steel finished with nickel and chrome plating. Steel T-spindle for extra clamping force.

Quick Action

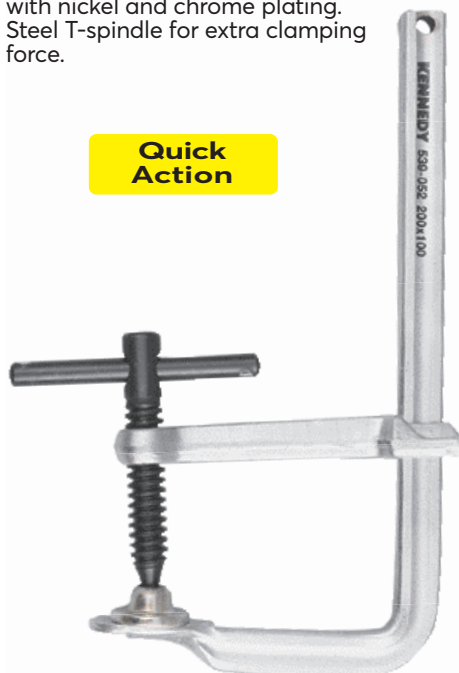

Capacity (mm)	Throat Depth (mm)	Order Code KEN-539
160	80	-0500K
200	100	-0520K
250	110	-0540K
300	110	-0560K
400	110	-0580K
500	110	-0600K
600	110	-0620K

Heavy Duty T-Handle Clamps

Manufactured from heat treated carbon steel for extra strength. Finished with nickel and chrome plating. Textured T-spindle for extra clamping force.

Thicker Section For Greater Strength



Capacity (mm)	Throat Depth (mm)	Order Code KEN-539
150	60	-4200K
200	100	-4220K
300	100	-4280K

IRWIN Clamp Heads

M130

A low cost alternative to a full size sash clamp. Clamp heads have a cast grey iron head and slide with a steel mainscrew. Clamp heads are designed to be fitted to a wooden batten 25mm (1") thick by 38mm (1 1/2") wide and any length.



Product Number	Weight each	Order Code MAR-597
M130	1.30kg	-3023C

Wooden Handle Speed Clamps

Manufactured from medium heat treated carbon steel with nickel and chrome plated finish. With a straight wooden handle for easy clamping.

Easy To Use

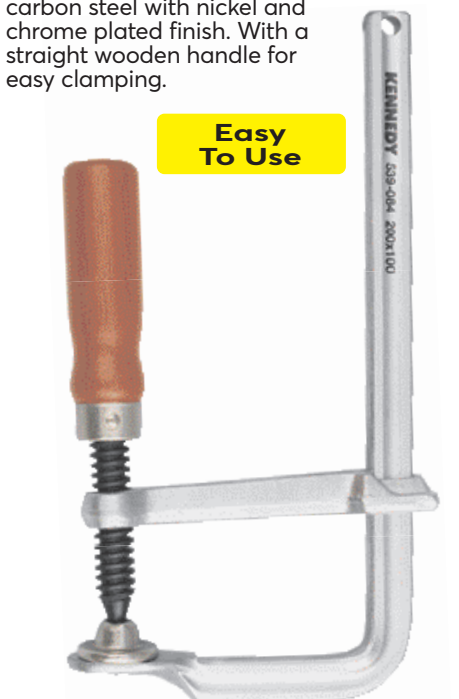

Capacity (mm)	Throat Depth (mm)	Order Code KEN-539
120	60	-0800K
160	80	-0820K
200	100	-0840K
250	130	-0860K
300	130	-0880K
400	110	-0900K
600	110	-0940K

Heavy Duty T-Handle Multi-Hold Clamps

Manufactured from heat treated carbon steel for extra strength. Finished with nickel and chrome plating. Textured T-spindle for extra clamping force. Supplied with three replaceable clamping pads for versatility.

Extremely Versatile



Capacity (mm)	Throat Depth (mm)	Order Code KEN-539
250	120	-4320K
300	120	-4340K
400	120	-4360K
500	120	-4380K
600	120	-4400K

Order online at cromwell.co.uk or call

North 0800 028 3602 | Central 0800 028 3191 | South 0800 028 3189

Clamps

Hand Tools

KENNEDY
QUALITY INDUSTRIAL TOOLING

One Handed Quick Action Bar Clamps

Kennedy Professional Dual Action Quick Clamps are designed for use one handed for speed and convenience. The pistol grip handle houses a ratchet clamping mechanism, that incrementally applies clamping force when you pull the trigger, to release or reposition the clamp jaw hold down the quick release button and slide the jaw along the bar. Can be used as a bar clamp or as a spreader simply by turning the handle around.

Features include: 90mm throat depth. Clamping force of up to 180kg. Quick release buttons for both jaws allows them to be positioned quickly anywhere on the bar and can be turned around to act as a spreader. Heavy duty steel bar. Non-slip clamp faces.



2-IN-1 CLAMP OR SPREADER

Capacity (mm)	Spread Range (mm)	Clamping Force	Order Code KEN-539
175	190 - 425	180kg	-3330K
325	190 - 580	180kg	-3360K
475	190 - 730	180kg	-3390K
625	190 - 880	180kg	-3420K
925	190 - 1125	180kg	-3450K

IRWIN Quick-Grip® Clamps

Evenly distributes up to 272kg (600lbs.) of sustained clamping pressure and is one of the top performing one handed bar clamps available. Ideal for heavy-duty applications such as installation, demolition and rough glue-up.



Product Number	Capacity (mm)	Spread Range (mm)	Clamping Force	Order Code IRW-565
10505942	150	235 - 378	272kg	-4920G
10505943	300	235 - 530	272kg	-4930H
10505944	450	235 - 683	272kg	-4940J
10505945	600	216 - 870	272kg	-4950K
10505946	900	235 - 1140	272kg	-4960L
10505947	1250	235 - 1496	272kg	-4970M

IRWIN Quick-Grip® Bar Clamps

Constructed of high-tech reinforced resin for strength and durability. Quick change jaw quickly converts from clamp to spreader. Patented pistol grip design enhances comfort and ease of use. Non-marring pads. Ideal for clamping/gluing, holding work for sawing/drilling, and positioning work for fastening.

Throat depth: 75mm.



Product Number	Capacity (mm)	Spread Range (mm)	Clamping Force	Order Code IRW-565
T546EL7	150	195 - 360	70kg	-8334J
T506QCEL7	150	195 - 360	100kg	-8260L
T512QCEL7	300	195 - 515	100kg	-8310P
T518QCEL7	450	195 - 665	100kg	-8318W
T524QCEL7	610	195 - 820	100kg	-8324C
T536QCEL7	915	195 - 970	100kg	-8330G

Quick-Grip® Micro Clamp/Spreader Bar

Specially designed for home, craft and hobby use. Ideal for delicate work requiring light clamping pressure. Easily converts into a spreader by reversing the clamp pads.

Capacity: 4"/100mm.



Product Number	Capacity (mm)	Order Code IRW-565
T53006EL7	100	-8329C

KENNEDY QUALITY INDUSTRIAL TOOLING **Gripper Clamp Set**

Spring loaded clamps, as above.

12 Piece Set Contents:
4x 120mm,
4x 150mm,
4x 210mm.

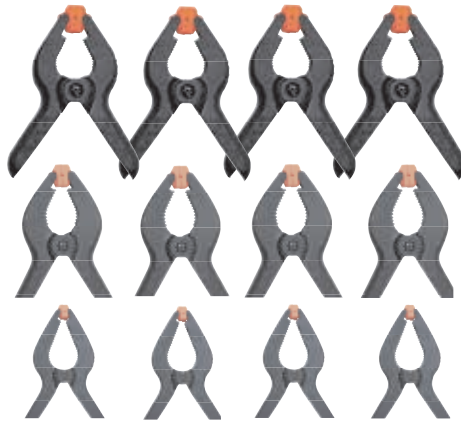

12
PIECES

Weight	Order Code
1564g	KEN-539
	-5400K

IRWIN **6 2/15cm Mini One Handed Bar Clamps, Blue, Pack 2**

- Sustained clamping force of 63kg/140lbs. allows for quick and even clamping on smaller lighter duty tasks
- One-handed quick release function for easier removal

new



Clamping Force kg	Clamping Force lb	Order Code
63	140	IRW-539
		-5462E

Mini Quick Grip Clamps, Pack of 2

- One-handed quick release trigger for easy and fast operation
- High-tech resin which is lightweight, sturdy and temperature resistant
- Fitted with non-marking, stay on pads that protect the surface



new

Capacity mm	Clamping Force kg	Order Code
300	63	IRW-565
		-8334C

Quick-Grip® Handi-Clamp™

Squeeze to adjust and click to release. Manufactured from high-tech resin for a lightweight and durable clamp.



Capacity (mm)	Weight each	Order Code
50mm	188g	IRW-565
100mm		-8620A
		-8640F

Sash Clamps

SG ductile cast iron heads and slides, bars are manufactured from bright drawn steel. Main screw and handles are made from high grade steel.



Unique spring load pin mechanism: for quick and easy adjustment. Can't drop out during use.

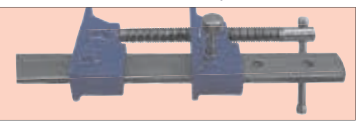

Capacity (mm)	Weight	Order Code
600	2.20kg	-3820K
910	2.75kg	-3840K
1220	3.25kg	-3860K
1670	4.00kg	-3880K

High Grade Steel for Heavy Duty Applications

90° Welding Angle Clamp

One man set up and operation, made from cast iron, copper plated spindle for spatter protection, T-Handle enables high pressure for secure clamping, easy fixing to a work bench or machine tool table.

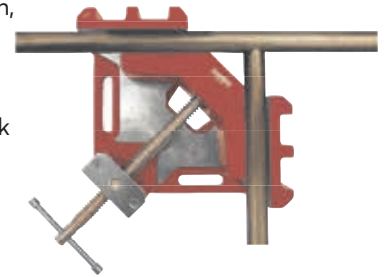

Capacity (mm)	Weight each	Order Code
60mm	05.3kg	-0360K
90mm	10.5kg	-0390K

IRWIN Sash Clamps

Cast iron heads and slides, bars are bright drawn steel and the main screw and handles are high grade steel. The tail slides are secured by a solid steel pin. Also available are lengthening bars, which increase the bar length.

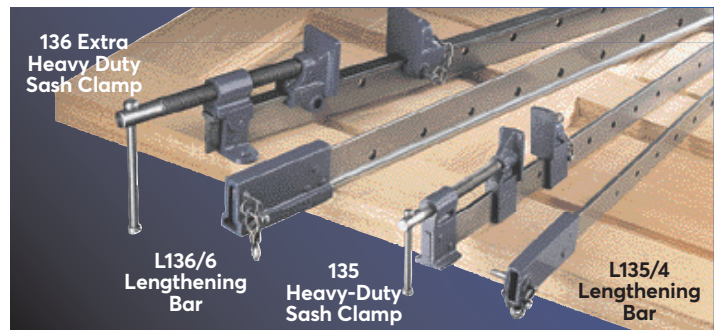

135 Heavy Duty Sash Clamp

With a 32 x 6mm (1 1/4" x 1/4") bar section. The slides and heads are flat bottomed to stand without support.

Product Number	Capacity (mm)	Weight each	Order Code
135/2	610 (24")	2.15kg	-8508G
135/3	760 (30")	2.40kg	-8510H
135/4	915 (36")	2.65kg	-8512J
135/5	1070 (42")	2.90kg	-8514K
135/6	1220 (48")	3.15kg	-8514S
135/7	1370 (54")	3.35kg	-8515T
135/9	1680 (66")	3.80kg	-8517W
Lengthening Bar			
L135/4	915 (36")	1.85kg	-8536W

136 Extra Heavy Duty Sash Clamp

Same as No.135, but with a 'T' section bar for extra resilience (as high as 1.9 tons). The fixed head can be bench mounted.

Product Number	Capacity (mm)	Weight each	Order Code
136/5	1070 (42")	4.85kg	-8520M
136/6	1220 (48")	5.25kg	-8521A
136/7	1370 (54")	5.85kg	-8522N
136/9	1680 (66")	6.45kg	-8524P
136/11	1980 (78")	7.15kg	-8527B
Lengthening Bar			
L136/6	1220 (48")	3.65kg	-8538X

Order online at cromwell.co.uk or call

North **0800 028 3602** | Central **0800 028 3191** | South **0800 028 3189**

KENNEDY QUALITY INDUSTRIAL TOOLING

Liquid Measures

Chemical and oil resistant polyethylene.

Graduations:

- ¼ ltr - 10ml,
- ½ ltr - 10ml,
- 1ltr - 10ml,
- 2ltr - 20ml,
- 3ltr - 50ml,
- 5ltr - 100ml.



Capacity	Weight each	Order Code KEN-540
¼ltr	45g	-5500K
½ltr	75g	-5520K
1ltr	100g	-5540K
2ltr	180g	-5560K
3ltr	260g	-5580K
5ltr	360g	-5600K

Heavy Duty Liquid Measures

Chemical and oil-resistant polyethylene. Integral dispensing spout. Can be used in conjunction with dispensing spouts listed below.

Graduations:

- ½ltr - ¼ and ½ltr,
- 1ltr - ¼, ½, ¾ltr,
- 2ltr - ½, 1, 1½ and 2ltr,
- 3ltr - 1, 1½, 2, 2½ and 3ltr,
- 5ltr - 1, 2, 3, 4 and 5ltr.



Capacity	Weight each	Order Code KEN-540
½ltr	60g	-5700K
1ltr	100g	-5720K
2ltr	180g	-5740K
3ltr	240g	-5760K
5ltr	340g	-5770K

Pouring Spouts

Flexible polyethylene, suitable for use with the spouted funnels and measures.

Suitable For	Weight each	Order Code KEN-540
½ & 1ltr Measures	5g	-5160K
2, 3, & 5ltr Measures	15g	-5170K

Tin-Plated Oil Supply Cans

With easy pour handles, extended spout with chain retained end cap and hinged lid cap.



Capacity litre	Weight each	Order Code KEN-540
3	562g	-2540K
5	702g	-2560K
10	1038g	-2580K

PRESSOL 20ltr Plastic Jerry Can

21-127 HDPE (high density polyethylene) jerry can complete with patented jerrycan locking cap and internally stored spout. Robust and impact resistant. UN Approved. Class 3.



Capacity	Order Code PRL-540
20ltr	-5610A

Plastic Funnels

Resistant to oil and chemicals. Heavy duty polyethylene which will not shatter or break in cold weather.



Diameter (mm)	Order Code KEN-540
55	-2812K
75	-2817K
100	-2822K
120	-2832K
150	-2842K

Plastic Funnel Set

Contents: 50, 75, 100 and 125mm.

4 PIECES



Number of Pieces	Order Code KEN-540
4	-2892K

Heavy Duty Plastic Funnel

With anti-splash rims



Diameter (mm)	Order Code KEN-540
160	-2912K
195	-2922K
235	-2932K
350	-2940K

Polyethylene Funnel with Lockable Lid

Screws into a standard 2" bung hole on a barrel. Includes a removable filter screen.

Size: 253mm x 200mm



Capacity	Order Code KEN-540
4.5ltr	-2680K

Plastic Jerry Cans

Secure water containers manufactured from food grade plastic available in 10, 15 and 20ltr capacities, fitted with a collared screw top for ease of refilling and a twist on-off tap for spill free dispensing.

The moulded handle design makes it ideal for transporting and storing water in and around the work place, home or when travelling.



Capacity litre	Type	Order Code KEN-540
10	Water	-6500K
15	Water	-6520K
20	Water	-6540K
35	Water	-6570K

Industrial Quality Plastic Funnel

Rectangular Suitable for use with petrol, oil, water etc.



Size (mm)	Weight each	Order Code KEN-540
250 x 180	210g	-2900K

Tin-Plated Indus Quality Funnel

Suitable for use with petrol, oil, water etc.



Diameter (mm)	Weight each	Order Code KEN-540
150	140g	-2600K
200	250g	-2800K

Metal Funnel with Plastic Spout & Filter

Sturdy metal construction complete with integral handle for ease of use, plastic spout and removable filter. High rim design guards against splashing. Flexible spout extension also available (KEN-540-2700K).



Diameter	Order Code KEN-540
170mm	-2690K
Flexible spout extension	-2700K

Plastic Funnel

With an removal filter, integral handle and rigid spout.



Diameter (mm)	Order Code KEN-540
160	-2962K

Plastic Funnel

With anti-splash rim, integral hanging hook and 300mm detachable flexible spout.



Diameter (mm)	Order Code KEN-540
160	-2997K

KENNEDY Rotary Pump
QUALITY INDUSTRIAL TOOLING

RP250
Cast iron pump, steel suction tube and spout. Suitable for lubricants and diesel (not anti-freeze). Suitable for container size 200ltr. Tube length 980mm. Inlet on pump 2" BSP and M59 x 5 male thread.



Discharge per Stroke	Weight each	Order Code
250ml 35ltr/min	5.7kg	KEN-540 -3100K

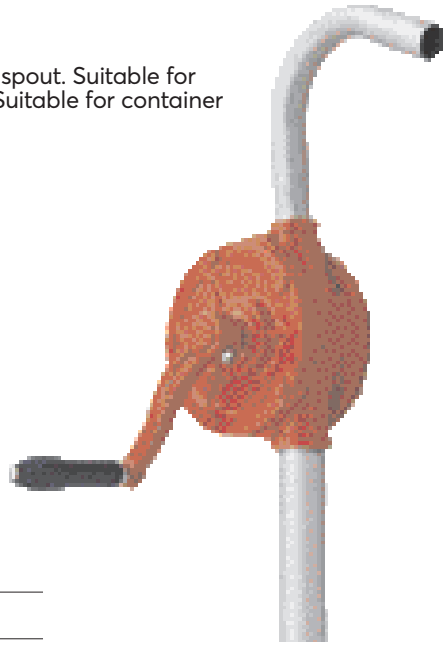

KENNEDY Syphon Pump
QUALITY INDUSTRIAL TOOLING

Flexible plastic outlet and semi-rigid inlet tubes. Hand pumping units incorporate one-way valves. Suitable for use with petrol, diesel and non-corrosive liquids. All tubes can be cut to length.

SPS/25 For use with containers up to 25ltr. Fitted with 30mm bung.

Tube length: inlet 410mm/outlet 530mm.

SPS/205 For use with containers up to 205ltr. Fitted with a 50mm threaded bung.

Tube length: inlet 860mm/outlet 1000mm.

SPH/205 Heavy duty, for use with containers up to 205ltr. Fitted with a 50mm threaded bung.

Tube length: inlet 860mm/outlet 1000mm.



Up to 25ltr

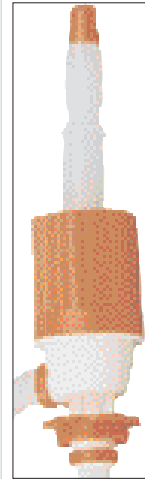

Up to 205ltr

SPS/25 has a squeeze action.
SPS/205 & SPH/205 have a plunger type action.

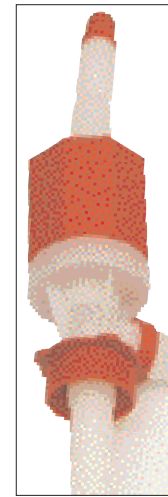

Up to 205ltr Heavy duty

Model Number	Suitable for Containers	Weight each	Order Code
SPS/25	25ltr	40g	-4000K
SPS/205	205ltr	80g	-4050K
SPH/205	205ltr	420g	-4150K

Lever Pump

LP300
Zinc chrome finish steel, telescopic suction tube. Suitable for lubricants, diesel and non-corrosive liquids. Suitable for container sizes 60 and 200ltr. Tube length 480 - 900mm. Inlet on pump 2" BSP and M59 x 5 male thread.

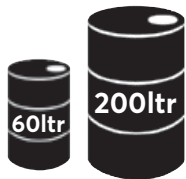

Discharge per Stroke	Weight each	Order Code
300ml	2.0kg	KEN-540 -3000K



YAMOTO Steel Lever Action Barrel Pump

Self adjusting telescopic suction tube. Comfortable handle grip. Suitable for lubricants & non-corrosive liquids.



Discharge per Stroke	Weight each	Order Code
300ml	2.14kg	YMT-540 -3001K

PRESSOL Diesel/Fuel Electrical Pump

The pump is designed exclusively for pumping diesel and fuel oil of the Hazard Class A III in areas that do not carry a risk of explosion. The temperature of the delivered fuel must be between -10°C and +35°C. 230V. Length of suction hose 1.6m, delivery hose 4m.



Not suitable for petrol/gasoline

Flow Rate	Weight each	Order Code
52ltr/min	6kg	PRL-540 -3500A

Rotary Chemical Dispensing Pump

Designed for use with fluids where a regular cast iron or steel barrel pump cannot be used. Pump body is made from glass filled polypropylene with Ryton veins. Seals are from Vitron rubber and all hardware is stainless steel. Strainer fitted at the suction tube inlet stops contaminants. Threaded polypropylene suction tube and a choice of 2" bung adaptors for use on both plastic and metal drums of capacities 50ltr and 205ltr. For use with water-based fluids, anti-freeze, acids, chemicals etc., in addition to all petroleum-based products. Delivery 5ltr per 20 turns of the handle.

DO NOT USE with acetone, lacquer, mineral oils, solvents or turpentine.

Discharge per Stroke	Weight each	Order Code
250ml	3kg	KEN-540 -3800K

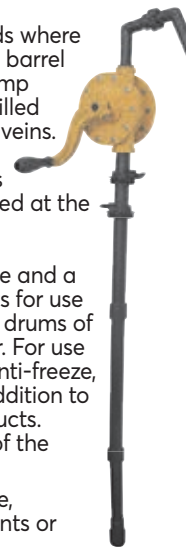

Double Diaphragm Fuel Transfer Pump

Heavy duty aluminium die-cast construction fuel transfer pump with a discharge rate of up to 1 gallon per 5 strokes. Stainless steel piston and fuel resistant hi-nitrile rubber diaphragm. 2" die cast bung adapter. Pump inlet is fitted with an easy to clean wire mesh screen filter. Telescopic suction tube, adjustable to fit 50 to 205ltr drums, with non-return valve. Easy dispensing through 2.4m (8') of antistatic neoprene rubber hose with die-cast dispensing nozzle.

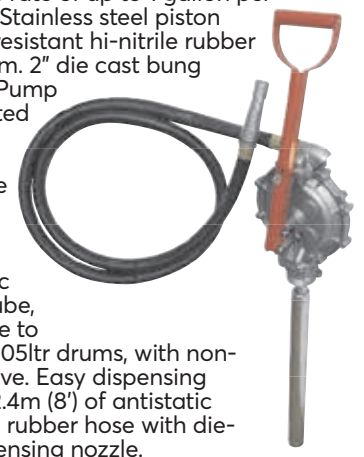

Discharge per Stroke	Weight each	Order Code
800ml	7.5kg	KEN-540 -3600K

KENNEDY
QUALITY INDUSTRIAL TOOLING

Dispensing Bottles

Manufactured from oil and chemical resistant polyethylene. With rigid applicator nozzles and sealing caps.



60ml Concertina Pump Action Bottle

Capacity (ml)	Weight each	Order Code
60	15g	-5000K

250ml Squeeze Bottle

Capacity (ml)	Weight each	Order Code
250	40g	-5020K
500	60g	-5040K

With 25° adjustable Brass Spout & Nozzle

Capacity (ml)	Spout Length	Weight each	Order Code
125	90mm	40g	-5100K
250	150mm	55g	-5120K
500	190mm	70g	-5140K

Heavy Duty Trigger Hand Sprayers

Manufactured from polyethylene, these robust trigger spray dispensers are suitable for many industrial applications. Will dispense various chemicals, water-based detergents, solvents and cleaning agents.



Capacity (ml)	Type	Weight each	Order Code
500	Industrial	79g	-5400K
740	Industrial	85g	-5420K
1000	Industrial	146g	-5440K

Dual Transfer Pump DTP500

Heavy-duty aluminium construction. Durable inlet and outlet valves. Suitable for the transfer of many different liquid types. Portable and easy to operate. Ideal for use in many home, industrial and farm applications.

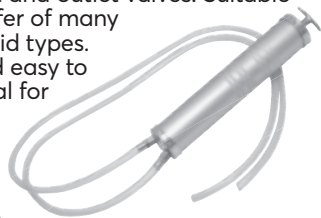

Capacity (cc)	Weight each	Order Code
500	878g	-3400K

Plastic Oil Cans

One-piece moulded plastic bodies with positive force feed pumps, supplied with nylon push-fit spouts.

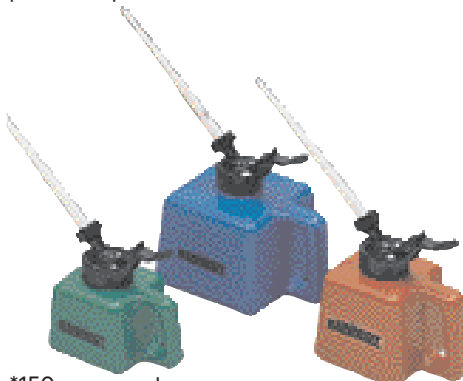

*150mm spouts
**230mm spouts

Capacity (cc)	Weight each	Order Code
350*	110g	-1880K
500*	120g	-1900K
1000**	170g	-1920K

Spare Spouts to Suit (Interchangeable)

Type	Spout Length	Weight each	Order Code
Nylon	230mm	8g	-1950K
Nylon	255mm	17g	-1970K

Metal Oil Cans

Enamel finish, heavy gauge, seamless metal-bodied oil cans. With positive force feed brass pumps and valves. Supplied with both rigid metal and flexible nylon threaded spouts.



Capacity (cc)	Weight per 10	Order Code
125	2.20kg	-1120K
250	2.90kg	-1250K
350	3.20kg	-1350K
500	3.20kg	-1500K
700	3.67kg	-1750K
1000	4.16kg	-1100K

Spare Spouts to Suit (Interchangeable)

Type	Spout Length	Weight each	Order Code
Flexible	150mm	170g	-1800K
Flexible	210mm	210g	-1850K

Oil Suction Gun SG500

Chrome finish. Suitable for rapid draining or filling of oil and other non-corrosive liquids.



Working pressure: 90psi/6.2bar.
Diameter: 63mm.
Overall length: 330mm.

Capacity (cc)	Weight each	Order Code
500	870g	-0380K

WESCO Plastic Oil Cans

Moulded plastic body pump oilers with nylon pump unit and 150mm spout.



(Flexible hose not supplied as standard)

Product Number	Capacity (cc)	Weight each	Order Code
350	350	120g	-9022N
500	500	140g	-9024Q

Metal-Bodied Oil Cans

Fitted spout with nylon pump unit.



Product Number	Capacity (cc)	Weight each	Order Code
3320	350	350g	-9043K
3340	500	370g	-9044L

PRESSOL Trigger Spray Economy Dispenser

Sprayer head with adjustable and closeable plastic nozzle. For water-based, non-aggressive liquids. Ideal for household use. HDPE (high density polyethylene).

Colour: orange.
Height: 280mm.
Base dia: 100mm.



Capacity (ml)	Weight each	Order Code
750	0.11kg	-5200A

Trigger Spray Industrial Dispenser

Sprayer head with adjustable and closeable plastic nozzle. Suitable for various chemicals. HDPE (high density polyethylene).

Colour: orange.
Height: 290mm.
Base dia: 100mm.



Capacity (ml)	Weight each	Order Code
750	0.12kg	-5250B

Barrel Adaptors

Threaded plastic adaptors to convert drums to use BSP fittings.

Orange (Trisure) - ADTS
Converts from 56 x 4 male to 2" BSP female.

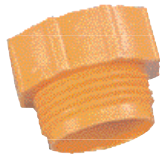

Grey - ADUSIBC
Converts from DIN61 male to 2" BSP female.



Black - ADDIN2XM
Converts from DIN61 male to 2" BSP male.



Yellow - ADDIN61
Converts from DIN61 female to 2" BSP female.



Blue (Mauser) - ADUSIBC
Converts from 70 x 6 male to 2" BSP female.

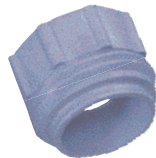

Brown - ADDIN71
Converts from DIN71 male to 2" BSP female.



Colour	Weight each	Order Code CTL-540
Orange	40g	-2050R
Grey	45g	-2051S
Black	37g	-2052T
Yellow	51g	-2053V
Blue	62g	-2054W
Brown	47g	-2055X

Rubber 'O' Rings

NBR70

Used in engines, gearboxes, shower heads and aircraft, garden hoses and pumps etc., Use as face to face gasket style seals or as shaft seals and allow both rotary and linear movement. Has a 70 Shore hardness and an operating temperature range of -30°C to +120°C. Highly resistant to many chemicals, petroleum, diesel, LPG etc. All sizes to BS1806.



Seal - ADOR
'O' ring for use with all above adaptors.

Weight each	Order Code CTL-540
4g	-2060Z

Steel Body

BT2SV

Lockable. Shut-off valve. Cast iron outlet spout.

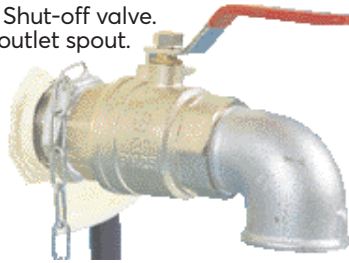

Weight each	Order Code CTL-540
2.6Kg	-2022H

Stainless Steel Body

BTSSS

Flame arrester. Spout rotates through 360°. Teflon seal. Heavy duty. Lockable.



Weight each	Order Code CTL-540
654g	-2012C

Large Bore Taps

2" BSP Thread
Polyethylene body
BTP2. EPT gasket. 2" tapered thread.



Weight each	Order Code CTL-540
255g	-2020F

Drum Treacle Tap

2" BSP Thread
Cast iron body (BTT2C) with brass faceplate for an excellent seal and easy flow control. Ideal for high viscosity fluids.

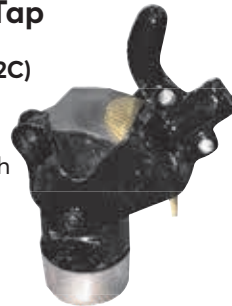

Weight each	Order Code CTL-540
1.5kg	-2023J

Brass Bod

125

Used to allow air to fill the vacuum left by dispensing...

For use in conjunction with 3/4" drum tap BSP three Nitrile seal

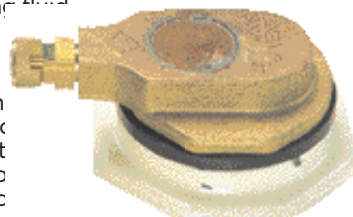

Weight each	Order Code CTL-540
462g	-2024K

KENNEDY Drum Taps
QUALITY INDUSTRIAL TOOLING

With 3/4" BSP male threads. Both models can be locked into the off position by use of a padlock or locking pin.

Polypropylene
Not suitable for petroleum based products.



Body	Weight each	Order Code KEN-540
Zinc-Plated	300g	-9000K
Polypropylene	100g	-9050K

Zinc Plated

Self-Closing/Safety Tap

3/4" BSP Thread

General-purpose safety taps for fluid dispensing on 210ltr drums. Standard alloy - BTSA. Lockable, nylon seal.

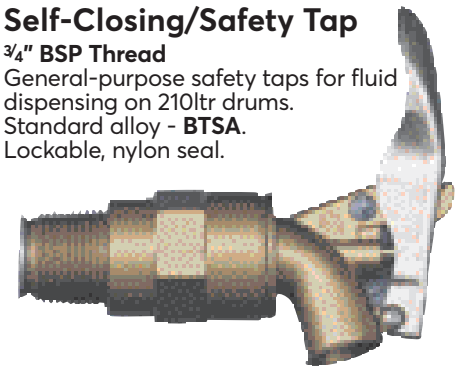

Weight each	Order Code CTL-540
158g	-2010A

Brass Body

BT2BV

Heavy duty. Self-closing.

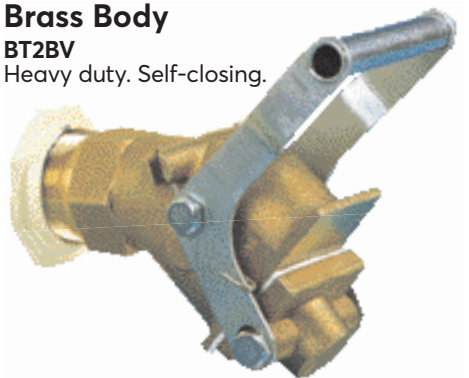

Weight each	Order Code CTL-540
3.0kg	-2021G

Alloy Flame Resistant

BTSAF

Alloy body, lockable, nylon seal with integral flame arrester.



Weight each	Order Code CTL-540
178g	-2011B

Order online at cromwell.co.uk or call

North 0800 028 3602 | Central 0800 028 3191 | South 0800 028 3189

KENNEDY Tilting Drum Cradle

Tilting Drum Cradle tips, rotates and locates 205ltr drums.

- Equipped with removable handle
- Powder coated finish.
- Large 2½" (63mm) non-sparking wheels making it suitable for use on rough flooring in gas/fuel plants.
- Maximum load 600lbs (273kgs).
- Unit comes flat packed.



Dimensions (H x W x L):
415 x 410 x 814mm.
Weight: 12.5kg.

Order Code
KEN-540
-4400K

Waste Oil Collection

These items are for the collection of waste oil prior to disposal in accordance with your local authority regulations.

Oil Drain Collector

This container is made of tough plastic, has an 8ltr capacity and can be closed for storage/transportation for disposal.



Type	Size	Shape	Weight each	Order Code
Collector	8ltr	Square	1.13kg	KEN-540
Pan	8ltr	Round	1.14kg	-4500K
Pan	16ltr	Round	5.30kg	-4520K

Oil Drain Pans

This waste oil pan is made of tough plastic and has an 8 or 16ltr capacity.



Galvanised Drip Trays

Galvanised steel self-colour. Reinforced beaded rim - acts as carrying handle. Available in capacities of 5L and 8L in plain or with mesh cover.



Description	Internal Dimensions Length x Width x Height	Weight each	Order Code
5L Plain Tray	540 x 345 x 50mm	1.6kg	-4210K
5L With Mesh	540 x 345 x 50mm	2.2kg	-4220K
8L Plain Tray	665 x 560 x 50mm	2.7kg	-4250K
8L With Mesh	665 x 560 x 50mm	3.8kg	-4260K

WESCO All-Purpose Drip Tray

For protecting floor surfaces and coverings to prevent any unsightly stains or puddles that would make the storage area floor dirty or slippery. Suitable for catching those small parts during maintenance. If placed under the catch tank while changing oil - any spillage is contained and dirt ratio changes it is ideal for catching bearings, springs etc preventing contamination. The tray is made of moulded plastic with integral carry handles.

Internal dimensions: 330 x 520mm

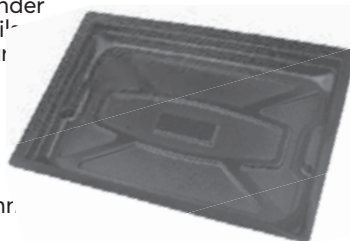

Product Number	Capacity Litre	Weight each	Order Code
350	10	519g	WES-540 -9200A

Oil Dispenser

6GR

Medium-duty oil dispenser suitable for medium grade oils. Full rotary action pump. Rotationally moulded, medium density polyethylene container complete with nozzle storage drip holster.



Capacity	Height	Order Code
17ltr	700mm	CTL-540 -2100F

Drum De-Heading Tools

Steel - DDHS

Suitable for removing tops of drums. Replacement blades available.

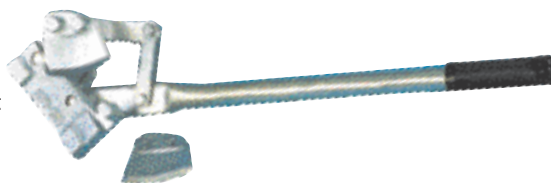

Description	Weight each	Order Code
De-heading Tool	3.33kg	CTL-540 -2040P
Replacement Blade	246g	-2041Q

90° Handle - Brass - DW2

Non-sparking brass construction. Suitable for 2" and ¾" bungs. Multi-purpose wrench head. Additional 1¼" socket for tightening drum taps.



Length: 300mm.	Weight each	Order Code
	819g	CTL-540 -2032N

Straight Handle - Steel Plated - DKS45

Suitable for steel or plastic drums. Non-slip rubber grip.



Description	Weight each	Order Code
Straight Handle - Steel	750g	CTL-540 -2030L

Straight Handle - Brass - DKB45

Non-sparking brass construction. Suitable for use with flammable materials. Non-slip rubber grip.



Weight each	Order Code
880g	CTL-540 -2031M

KENNEDY Pneumatic Fluid Extractor
QUALITY INDUSTRIAL TOOLING

FEBK10

Pneumatic fluid extractor for use in draining engine oil, water, fuel and hydraulic fluids from vehicle engines and other mechanical equipment, bleeding brake/clutch fluid and collection of other non-corrosive fluid spillage. High capacity 10ltr fluid reservoir ideal for garage, extension tube storage, used for workshop and on-site use. Supplied with 1500 x 15mm initial tubing with extension tubes; 700 x 6mm, 360 x 10mm, 310 x 6mm and 380mm brake bleeder attachment. Air supply 70-110psi (5-8bar), air consumption 180ltr/min, vacuum (maximum) 500mm HG, extraction rate 2.5ltr/min., air inlet size 1/4" BSP.



Weight each	Order Code
3.5kg	KEN-540 -4700K

Mobile Waste Oil Drainer

ODB300

This sturdy mobile polyethylene container is for the collection of waste oil draining by gravity from engines/gearboxes. It has a capacity of 30ltr and a float level indicator to let you know when you are nearing its full capacity. The polyamide base is fitted with heavy-duty castors and a handle for easy manoeuvrability. The centre shaft is height adjustable from 900 to 1600mm with a 395mm diameter polypropylene drain pan, the pan is fitted with an anti-splash mesh.



Weight each	Order Code
11.1kg	KEN-540 -4600K

Pneumatic Grease Gun

Pneumatic PG400

Chrome-plated steel body, enamel finish gun, offset nozzle. Cartridge, bulk or suction fill. For plant and factory maintenance, fleet service etc. Can be connected to air brake systems on lorries. Suitable for medium greases.



400cc

Working pressure: 3600psi/250bar.
Diameter: 56mm.
Overall length: 400mm.

Capacity (cc)	Weight each	Order Code
400	1.90kg	KEN-540 -0360K

PNEUMATIC

Pistol Type Adjustable Angle Pneumatic Grease Gun

PGC400

360° handle rotation. Continuous flow. Chrome plated steel body and enamel finish gun. Offset nozzle. Suitable for medium grease. 14oz cartridge - bulk, suction or pump fill. Can be connected to the air brake systems on lorries. 1200 - 6000psi based on 30 - 150psi feed.

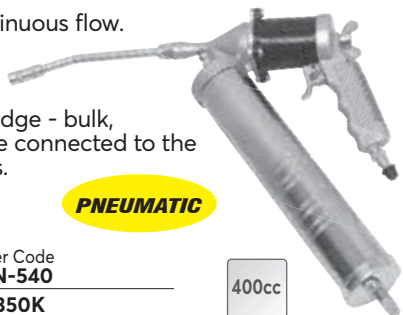

PNEUMATIC

Capacity (cc)	Weight each	Order Code
400	1.88Kg	KEN-540 -0350K

400cc

Direct Feed System

Lever Type LP12.5

Direct high pressure lubricating system with centre pump, metal dust cover/lid with integral stabiliser and fixing mechanism. Flexible delivery tube with offset nozzle. Suitable for medium greases.

Discharge per stroke: 3.8cm³,
Tube length: 375mm,
Inlet on pump max: 260mm.
Barrel (illustrated) available separately.



Description	Capacity (kg)	Weight each	Order Code
Feed System Barrel	12.5	4.90kg	KEN-540 -0540K -0580K

High Pressure Grease Dispensing Pump

An easy to operate high pressure manual greasing system that is used to provide volume greasing where power is not available. Used for clean greasing of machinery, equipment and vehicles using grease up to and including NLGI 2. The pump has steel construction with aluminium cast head and solid steel pumping chamber. Complete with drum cover, follower plate, 1220mm (48") flexible grease hose fitted with professional 4-jaw coupler. For use with 12.5kg grease pails. Pump develops 3500psi (240bar) and delivers 1.25gm per stroke (1.2oz per 28 strokes).



Weight each	Order Code
4.8kg	KEN-540 -3640K

Air Operated Grease Pump

Grease set suitable for 15kg drums.

Equipped with:

- 1 x Air-operated grease pump ratio 60:1 Mod. 660 12-16kg
- 1 x Lid for pumps with shank Ø 30 mm
- 1 x Follower plate for pumps with shank Ø 30mm
- 1 x Grease control gun with flexible hose and 4-jaws coupling
- 1 x Grease pump handle
- 1 x R2 hose 1/4" M-F length 3m

Specification:
Weight: 11,16 kg.
Volume: 0,056 m³.

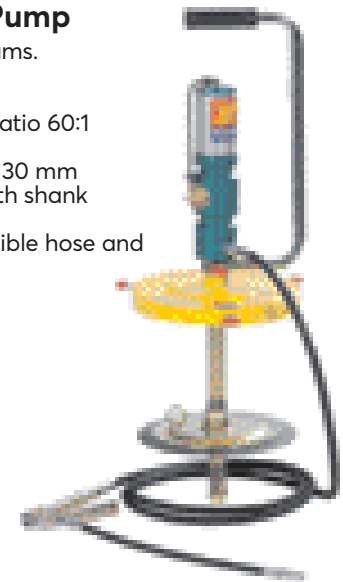

Product Number	Suitable for Containers	Order Code
013-1099-000	15kg	CTL-540 -4536H

Order online at cromwell.co.uk or call

North **0800 028 3602** | Central **0800 028 3191** | South **0800 028 3189**



Grease Guns

Lever LG200

Chrome plated steel body, handle and offset nozzle. Suction fill only. Suitable for medium/heavy greases.

Working pressure: 3000psi/206bar.

Diameter: 45mm.

Overall length: 300mm.



Capacity Bulk Fill	Order Code
200cc	KEN-540
	-0150K

Lever LG400

Chrome-plated steel body, rubber grip and offset nozzle.

Cartridge, bulk or suction fill.

Suitable for medium/heavy greases.

Working pressure: 4500psi/310bar.

Diameter: 56mm.

Overall length: 370mm.

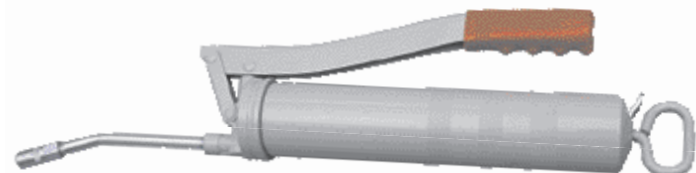

Capacity Bulk Fill	Capacity Cartridge	Order Code
400cc	400g/14oz	KEN-540
		-0250K

YAMOTO Grease Gun - Lever Action

500c/ 14oz Cartridge, bulk or suction fill. Air bleed screw. Comfortable Handle Grip.



Capacity Bulk Fill	Capacity Cartridge	Order Code
500cc	400/14oz	YMT-540
		-0251K

WANNER Hand Compressor 400CC Cartridge - Body Only

37540

This Swiss range of grease guns are produced for quality and reliability. Abnox Wanner grease guns are designed to operate under more arduous conditions and having a long life means that these grease guns are more economical in the long term.



Capacity (cc)	Order Code
400	CTL-540
	-4528A

Lever LG500

Chrome-plated steel body and handle, offset nozzle. Cartridge, bulk or suction fill.

Suitable for medium/heavy greases.

Working pressure: 4500psi/310bar.

Diameter: 45mm.

Overall length: 300mm.

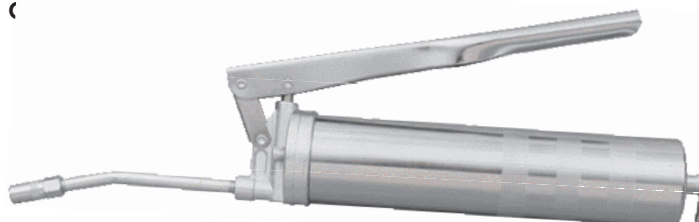

Capacity Bulk Fill	Capacity Cartridge	Order Code
500cc	450g/16oz	KEN-540
		-0300K

Lever LG-PRO500

Enamel finish steel body, offset nozzle.

Cartridge, bulk or suction fill.

Suitable for medium greases.

Working pressure: 6000psi/400bar.

Diameter: 56mm.

Overall length: 340mm.



Capacity Bulk Fill	Capacity Cartridge	Order Code
500cc	400g/14oz	KEN-540
		-0340K

FUCHS Reiner Grease Gun

A two handed grease gun that is compatible with 500g and 600g cartridges. s 400psi, a higher pressure than many manual guns.



Order Code
FCH-740
-6936E

LUMATIC Oil Gun

Side Lever OLGH/CV

Supplied with 150mm steel delivery tube and a hydraulic connector with check valve for high pressure.

Diameter: 56mm.

Overall length: 365mm.



Capacity (cc)	Order Code
500	CTL-540
	-4538G

Push-Type Grease Guns

Robust metal body. Versatile one-hand operation. Supplied with universal nozzle connector for standard grease fittings.



Capacity	Weight each	Order Code
35cc	258g	KEN-540 -0020K
140cc	436g	-0040K

Professional Grease Gun

Trigger TG120

Chrome-plated steel body, straight nozzle. Cartridge or suction fill. Suitable for soft/medium greases.

Working pressure: 2900psi/200bar.

Diameter: 36mm.

Overall length: 253mm.



Capacity	Weight each	Order Code
Bulk Fill Cartridge	760g	KEN-540 -0100K
120cc		

Grease Guns

Trigger TG-PRO500

Enamel finish steel body, straight nozzle. Cartridge, bulk or suction fill. Suitable for medium greases.

Working pressure: 3900psi/260bar.

Diameter: 56mm.

Overall length: 340mm



Capacity	Weight each	Order Code
Bulk Fill Cartridge	1.35kg	KEN-540 -0320K
500cc		

Cordless Grease Gun

CPG18V

Featuring LCD battery condition indicator, air bleed and a heavy-duty aluminium pressure head.

Flow rate: 100g/min

Hose length: 700mm

Pressure: 8000psi

Supply with: 18V 1.7Ah battery, mains charger and carry case

Suitable for screw type and standard 400g cartridges, manual or bulk filling



Capacity	Order Code
400cc	SLY-540 -1328F

YAMOTO Steel Push-Type Grease Gun

PTG1200

Bulk or suction fill. Corrosion protective electro-plated finish. Polished nozzle and galvanised plunger assembly. Suitable for medium or heavy greases.



Capacity	Weight each	Order Code
120cc	415g	YMT-540 -0030K

Piston-Type Grease Gun

GGP120

Bulk or suction fill. Corrosion protective electro-plated finish. Galvanised plunger assembly. Suitable for medium or heavy greases.



Capacity	Weight each	Order Code
Bulk Fill Cartridge	505g	YMT-540 -0370K
120cc		

Steel Grease Gun

GGP400 - Pistol Type Grease Gun

400g (14oz) cartridge, bulk or suction fill. Galvanised trigger body. Galvanised nozzle and plunger assembly. Air bleed button. Comfortable grip. Suitable for medium or heavy greases.



Capacity	Weight each	Order Code
Bulk Fill Cartridge	1.50kg	YMT-540 -0360K
400cc		

LUMATIC Grease Gun

TelescopicMPO

Telescopic hand grease gun with metal body and push-on connector.

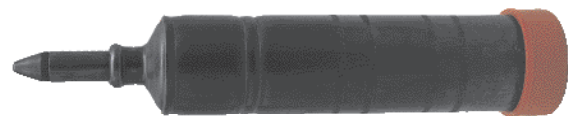

Capacity	Weight each	Order Code
60cc	100kg	CTL-540 -4536N

Order online at cromwell.co.uk or call

North 0800 028 3602 | Central 0800 028 3191 | South 0800 028 3189



Hydraulic Grease Nipple Kit

Contents

Straight:
 1/4" BSP,
 1/8" BSP,
 M8 x 1.25
 1/4" BSF.

45°:
 M8 x 1.25
 M10 x 1.50.

90°:
 1/4" BSF.

140
 PIECES

Order Code
KEN-541
-5140K



Hydraulic Grease Nipples

For use with Kennedy greas guns and all other hydraulic grease equipment.

Straight Hook-On



Thread Size	Weight Per 100	Order Code KEN-541
1/8" BSP(T)	1.30kg	-1070K
1/4" BSP(T)	2.00kg	-1090K

45° Type



Thread Size	Weight Per 100	Order Code KEN-541
1/8" BSP(T)	1.30kg	-0610K
1/4" BSP(T)	1.95kg	-0690K
1/4" BSF	0.70kg	-0770K
M6 x 1	0.70kg	-0850K
M8 x 1.25	0.60kg	-0930K
M10 x 1.5	1.25kg	-1010K

Hydraulic Connectors

Securely grips the grease nipple while in use.

4-Jaw

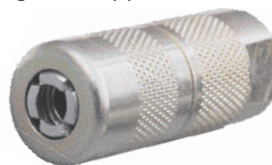

Thread Size	Weight each	Order Code KEN-541
1/8" BSP(T)	40g	-0480K

Straight-Type



Thread Size	Weight Per 100	Order Code KEN-541
1/8" BSP(T)	0.60kg	-0600K
1/4" BSP(T)	1.10kg	-0680K
1/4" BSF	0.30kg	-0760K
M6 x 1	0.30kg	-0840K
M8 x 1.25	0.50kg	-0920K
M10 x 1.5	0.60kg	-1000K

90° Type



Thread Size	Weight Per 100	Order Code KEN-541
1/8" BSP(T)	1.30kg	-0630K
1/4" BSP(T)	2.10kg	-0710K
1/4" BSF	0.70kg	-0790K
M6 x 1	0.60kg	-0870K
M8 x 1.25	0.55kg	-0950K
M10 x 1.5	1.30kg	-1030K

Hook-On

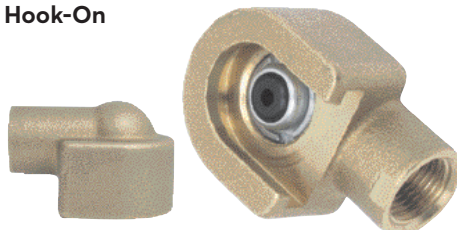

Thread Size	Weight each	Order Code KEN-541
1/8" BSP(T)	40g	-0490K

Rubber & Nylon Hoses

Suitable for high pressure use with 1/8" BSP end fittings. Rigid tubes are solid steel for use with all grease guns.



Product Number	Size & Type	Weight each	Order Code CTL-540
RF12	12" Rubber	95g	-4612N
RF12/N	12" Nylon	45g	-4613P
RF9	9" H/P Rubber	80g	-4616S
SRT10	10" Rigid	75g	-4621Y
SRT6	6" Rigid	40g	-4622Z

Metal & Flexible Hoses

For use with Kennedy grease guns, flexible hoses improve access in confined spaces, 1/8" BSP connecting threads.



Bore x Length	Type	Weight each	Order Code KEN-540
150mm	Offset Metal	40g	-0390K
8x230	Nylon	30g	-0400K
8x300	Nylon	40g	-0410K
8x500	Nylon	40g	-0420K
11x230	Rubber	60g	-0430K
11x300	Rubber	70g	-0440K
11x500	Rubber	90g	-0450K

LUMATIC Hydraulic Connectors

Giant Hook-On Type



Product Number	Weight each	Order Code
GHOC1	160g	-4603D

Push-on Type



Product Number	Weight each	Order Code
POC1	10g	-4610L

Hydraulic Heavy Duty



Product Number	Weight each	Order Code
HC1	35g	-4604E

Hydraulic Standard Duty



Product Number	Weight each	Order Code
HC5	45g	-4605F

Conical-Type



Product Number	Weight each	Order Code
CC1	10g	-4602C

Lub-Type For Concave Nipples



Product Number	Weight each	Order Code
LC1	15g	-4609K

Slide-on Type With Knuckle Joint



Product Number	Weight each	Order Code
SOC2	120g	-4619S

KENNEDY Magnet Extending Pick-up Sweeper

High power magnet for easy pick-up and release of metal objects. Can be used for scrap and ferrous debris. Permanent magnet, never needs to be re-magnetised. Lightweight. Chrome-plated and corrosion-resistant.

Maximum lifting weight: 20lbs/9.0kg.



Working Length	Weight each	Order Code
104cm	1430g	-0220K

ECLIPSE MAGNETICS Magnetic Vee Blocks

Powerful magnet in a precision-ground mild steel case. The vee block can be used on its base, side or end to hold components for machining operations. The large vee can hold diameters up to 65mm and the smaller vee diameters up to 20mm. The on/off switch toggles both vees simultaneously. Operations for holding cylindrical and complex workpieces for marking, spark erosion, grinding, measurement and inspection operations.

Magnetic adhesion (top and bottom faces): 200/150kg.



Dimensions (mm)	Weight each	Order Code
Single Vee Blocks		
80x70x95	3.15kg	-0475A
101x70x95	4.00kg	-0473X
Matched Pair		
101x70x95	9.00kg	-0474Y

KENNEDY Magnetic Vee Block

Ideal for holding cylindrical workpieces for grinding application. The adhesion will simultaneously hold the workpiece and vee-block to any flat ferrous surface.

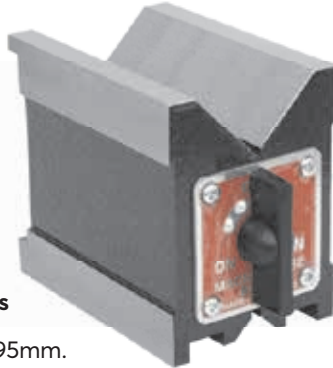

Dimensions W x L x H: 70 x 102 x 95mm.

Magnetic Adhesion	Weight each	Order Code
50kgf	4.00kg	-1100K

Magnetic Holder

Incorporates vee and plain faces. Enables accurate positioning of workpieces relative to each other, also secures sheets, bars and tubes.

Dimension (W x L x H): 108 x 108 x 104mm.



Magnetic Adhesion	Weight each	Order Code
100kgf	6.00kg	-1300K

Magnetic Long Reach

Long reach handle. High power magnet for easy pick-up and release of metal objects. Can be used for scrap and ferrous debris. Spring-loaded magnet release. Permanent magnet, never needs to be re-magnetised.

Maximum lifting weight: 8lbs/3.6kg.



Working Size	Weight each	Order Code
90mm Dia.	693g	-0180K

Magnetic Pick-up Tool

High power magnet for easy pick-up and release of metal objects. Can be used for scrap and ferrous debris. Spring-loaded magnet release. Permanent magnet, never needs to be re-magnetised.

Maximum lifting weight: 10lbs/4.5kg.



Working Size	Weight each	Order Code
100mm dia.	634g	-0160K

Magnetic Link

Two magnetic units joined by an adjustable steel strap (82mm long). Capable of holding at many different angles.

Single link base dimensions (L x H x V) 60 x 30 x

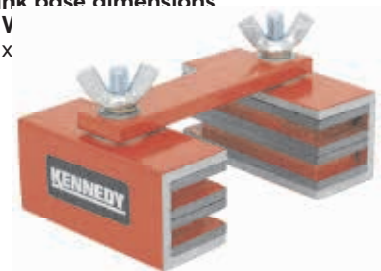

Magnetic Adhesion	Weight each	Order Code
13kgf	350g	-1400K

Magnetic Plate Drag E964

This powerful magnetic drag is manufactured with ferrite magnets. It enables quick and safe lifting and transportation of steel sheets. The grip is also used as a lever for disengaging the workpiece.



Base Size (mm)	Weight each	Order Code
118 x 98 x 38	2.80kg	-0493C

Recovery Magnet E936

Suitable for retrieving metallic objects from behind machines etc.

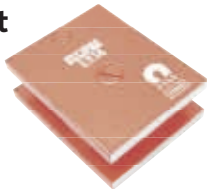

Base Size (mm)	Weight each	Order Code
83 x 36 x 102	1.40kg	-0476H

Demagnetiser

Any workpiece in materials such as tool and high speed steel will retain some magnetism after being held by a magnetic chuck. For further operations this may need to be demagnetised efficiently. Supplied complete with 1.8m cable.



Dimensions (mm)	Weight each	Order Code
150x87x117	3.80kg	-7295E

Magnetic Pick-up Wand

High power magnet for easy pick-up and release of metal objects. Can be used for scrap and ferrous debris. Permanent magnet, never needs to be re-magnetised. Lightweight. Chrome-plated and corrosion-resistant.

Maximum lifting weight: 14lbs/6.35kg.



Working Length	Weight each	Order Code
140mm	567g	-0200K

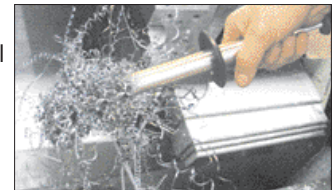

Order online at cromwell.co.uk or call

North **0800 028 3602** | Central **0800 028 3191** | South **0800 028 3189**

1045

Magnetic Tooling

Hand Tools



Magnetic Trays

For holding metal items such as nuts, bolts, washers etc.

Dish
For use in high and confined spaces with rubberised magnetic base mat to protect work surface.



Size (mm)	Weight each	Order Code
150 dia.	375g	KEN-553 -0250K

Rectangular Tray
For holding larger items.



Size (mm)	Weight each	Order Code
242 x 142	720g	KEN-553 -0300K

Telescopic Pick-up Tool

High power magnet, slimline contoured handle.



Extended Length (mm)	Max Lift weight	Order Code
550 (22")	4lbs/1.8kg	KEN-553 -0100K

Pen Type Pick-up Tool

Pen-type with pocket clip, high power magnet.



Extended Length (mm)	Max Lift weight	Order Code
610 (24")	4lbs/1.8kg	KEN-553 -0120K

Adjustable Pen-Type

Pen-type handle with pocket clip, multi-directional head.



Extended Length (mm)	Max Lift weight	Order Code
610 (24")	1.5lbs/680g	KEN-553 -0140K

Flexible Pick-up Tool

Fully adjustable shaft, high power magnet.



Extended Length (mm)	Max Lift weight	Order Code
455 (18")	1.1lbs/500g	KEN-553 -0130K

BAHCO

Magnetic Pick-up Tool with Light 2535L

Telescopic magnetic pick-up tool with light.



Extended Length (mm)	Weight each	Order Code
750 (30")	50g	BAH-553 -2535L

Magnetic Parts Tray

Rustproof stainless steel tray fitted with 4x 85mm magnets in a non-marking cover which attaches to any ferrous surface. For retaining hand tools and fasteners, ideal for applications where nuts, bolts and parts could get lost.



Bottom of tray



Size (mm)	Weight each	Order Code
295x270x42	1.60kg	KEN-553 -0270K

Claw/Magnetic Pick-up Tool with LED

Flexible spring steel stem with magnetic tip, ideal for recovery of small objects. Four retractable adjustable steel claws. Fitted with LED. Chrome plated and corrosion-resistant. Magnetic pull 1kg. Includes 3x LR44 batteries and battery protector.



Product Number	Length (mm)	Order Code
PTM600	600	KEN-553 -0340K

Telescopic Magnetic Pick-up Tool with LED

Telescopic with flexible head and magnets fitted to head and base. Fitted with LED. Knurled grip. Pocket size. Belt grip. Magnetic pull 2.27kg. Includes 4x LR44 batteries and battery protector.



Product Number	Extendable Length	Order Code
KTM583	175 - 583mm	KEN-553 -0360K



Rubber Covered Neodymium Pot Magnets

Male Thread

Neodymium iron boron 'rare earth' material. Strongest magnet material available. 80°C max operating temperature.



Dia. x Height (mm)	Thread Size	Holding Force (kg)	Order Code
Male Thread			
22 x 6.0	M4	5.0	ECL-553 -0414G
43 x 6.0	M4	8.5	-0414L
66 x 8.5	M5	18.0	-0414Q
88 x 8.5	M8	42.0	-0414W
Female Thread			
22 x 6.0	M4	11.5	-0414H
43 x 6.0	M4	10.5	-0414M
66 x 8.5	M5	15.0	-0414R
88 x 8.5	M8	17.0	-0414X



Hold Fast

Suitable for work holding and work handling. Supplied complete with release screw carry handle.



Dia. x Height (mm)	Mag. Adh.	Weight each	Order Code
44.5x44.5	20kg	0.55kg	ECL-553 -0478B
54.0x50.8	40kg	0.95kg	-0480D
69.9x63.5	88kg	1.95kg	-0482F

Variable Angle Magnetic Clamp

Can be set to any angle from 25° to 280°, the main angles of 90°, 60°, 45° and 30° are marked for quick reference. For holding tube or sheet for welding and assembly applications.



Length (mm)	Weight each	Order Code
194 x 205	500g	ECL-553 -0488S

Magnetic Strip

Suitable for door closures and sign/notice holding.

Width: 3.6mm.

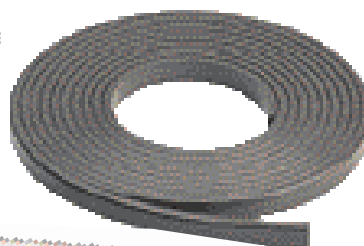

Length (mm)	Weight each	Order Code
*150	42g	ECL-553 -0493Z
2000	255g	-0493T

Neo-Hold Gripping Magnet

A high power gripping magnet achieved by two poles close together on one face. Thus a greater holding power is created, more than a pot or button magnet of a similar size. Ideal for confined work areas where more holding power is required.



Dimensions (mm)	Weight each	Order Code
12.7x11.8x5.5	10g	ECL-553 -0520A
15.9x15.8x5.5	18g	-0521B
22.2x20.5x5.5	40g	-0522C
25.4x25.5x5.5	25g	-0523D



Neodymium Countersunk Shallow Pot Magnets

Neodymium iron boron 'rare earth' material. Strongest magnet material available. 80°C max. operating temp. Zinc plated body.



Dia. x Depth (mm)	Order Code ECL-553
16 x 4.5	-0496G
20 x 6.0	-0496J
25 x 7.0	-0496L
32 x 7.0	-0496N
40 x 8.0	-0496Q

Neodymium Pot Magnets

Neodymium magnet in a cylindrical brass pot. Assembled with steel pole pieces to give a multi-pole effect which gives superior grip at the contact face ideal for clamping or lifting application. Ideally work at temperatures up to 80°C, but have a maximum working temperature of 100°C.



Diameter (mm)	Depth (mm)	Order Code ECL-553
Deep		
6	20	-0350A
8	20	-0351E
10	20	-0352B
13	20	-0353C
16	20	-0354D
20	25	-0355E
25	35	-0356F
32	40	-0357G
Shallow		
6	4.5	-0360K
8	4.5	-0361T
10	4.5	-0362M
13	4.5	-0363N
16	4.5	-0364V
20	6.0	-0365P
25	7.0	-0366W
32	7.0	-0367R
Shallow with Thread		
6	4.5	-0370V
8	4.5	-0371W
10	4.5	-0372X
13	4.5	-0373Y
16	4.5	-0374Z
20	6.0	-0375A
25	7.0	-0376B
32	7.0	-0377C

Disc Magnets

Nickel plated neodymium disc and block magnets. Magnetic poles on both faces, supplied in tubes. Maximum working temperature 100°C.



Dia. x Depth (mm)	Pack Quantity	Order Code ECL-553
Disc		
3 x 2	10	-0514C
4 x 2	10	-0514F
4 x 3	10	-0514J
4 x 4	10	-0514M
5 x 2	10	-0514Q
5 x 3	10	-0514T
5 x 5	10	-0514X
6 x 3	10	-0515A
6 x 4	10	-0515D
8 x 4	10	-0515G
9 x 3	10	-0515K
10 x 3	10	-0515N
10 x 5	10	-0515R
15 x 3	3	-0515V
20 x 3	3	-0515Y
20 x 10	1	-0516B
Block		
25 x 10	4	-0516E
25 x 10	4	-0516H

KENNEDY Magnetic Hold Fast

Positive gripping pot magnets supplied with screw-down release handle. Can be used singly or in multiples for making welding or other jigs. With M8 x 1.25 thread.



Depth: 35mm.

Dia. (mm)	Magnetic Adhesion	Weight each	Order Code KEN-554
40	20kgf	590g	-1200K
50	40kgf	955g	-1240K

Magnetic Quick Clamp

For fast accurate holding.



Dimensions (W x L x T):
65 x 110 x 15mm.

Angles	Weight each	Order Code KEN-554
30°, 90° & 135°	270g	-1700K

Channel Magnet

Designed to give maximum grip within channels or slots. Able to grip non-uniform workpieces.



Dimensions L x W x H (mm)	Weight each	Order Code KEN-554
130 x 30 x 13	250g	-3500K

Power Magnets

A square horseshoe magnet. Supplied with plain fixing holes.



Kg pull (max):
25mm - 4.5, 30mm - 9.0, 40mm - 11.8.

Size (mm)	Weight each	Order Code KEN-553
25 x 40 x 20	60g	-8120K
30 x 45 x 30	120g	-8130K
40.5 x 57 x 35	180g	-8140K

Ferrite Shallow Pot Magnets

Manufactured from ceramic ferrite material. Suitable for holding machine tool accessories with M6 threads or building into jigs.



Heavy Duty L-bolt

Ř x Width (mm)	Weight each	Order Code KEN-553
66 x 10.7	220g	-7020K
76 x 12.5	300g	-7040K
100 x 15.5	610g	-7060K

J-bolt



Size (mm)	Weight each	Order Code KEN-553
46 x 10.7	90g	-8900K
56 x 10.7	130g	-8910K
66 x 10.7	190g	-8920K

Bar Magnets

A range of one-piece cylindrical magnets with opposing poles at either end. Permanently magnetic.



Dia. (mm)	Depth (mm)	Weight Per 100	Order Code KEN-553
6.0	20 (3/4")	0.44kg	-8050K
8.0	25 (1")	1.00kg	-8060K
10.0	30 (1 1/4")	1.90kg	-8070K

Button Magnets

A horseshoe type cylindrical magnet. Opposing poles are at the same end of the magnet separated by a slot. Supplied with a plain bore and keeper. Permanently magnetic.



Diameter (mm)	Depth (mm)	Weight Per 100	Order Code KEN-553
12.7 (1/2")	9.5	0.87kg	-8210K
20 (3/4")	12.5	2.00kg	-8220K
25 (1")	16.0	5.60kg	-8230K
32 (1 1/4")	19.5	13.0kg	-8240K

Shallow Pot Magnets

North polarity in centre separated from opposing pole by a continuous slot. For use in areas of restricted height. Supplied with plain bore fixing hole/keeper. Permanently magnetic.



Diameter (mm)	Depth (mm)	Weight Per 100	Order Code KEN-553
20 (3/4")	7.8	1.75kg	-8260K
28.5 (1 1/8")	8.7	4.70kg	-8270K
38 (1 1/2")	10.6	9.70kg	-8280K

Deep Pot Magnets

North polarity in centre separated from opposing pole by a continuous slot. Ideally suited for gripping applications. Supplied with M5 x 1 threaded bore fixing hole and keeper. *M3 x 0.5



Diameter (mm)	Depth (mm)	Weight Per 100	Order Code KEN-553
9.5 (3/8")*	15.1	2.00kg	-8290K
17.5 (1 1/8")	16.0	2.70kg	-8310K
20 (3/4")	18.0	4.50kg	-8320K
27 (1 1/8")	25.4	9.80kg	-8330K
35 (1 3/8")	30.0	28.9kg	-8340K

Set

2 each: 12.7mm button.
1 each: 17.5mm deep button,
20mm button and 20mm pot.



Weight each	Order Code KEN-553
90g	-9000K

Order online at cromwell.co.uk or call

North 0800 028 3602 | Central 0800 028 3191 | South 0800 028 3189



Torque Drivers

Can indicate torque in two ways - measures and displays torque as it is applied, or measures and displays the maximum torque used, after it has been applied. Ideal for the electronics, electrical and domestic appliance industries. Stainless steel shafts coloured aluminium handles and scaled nylon dials. 1/4" hex drive. Dual scale. Manufactured to **ISO 6789 : 2003**. (Accuracy ±6% of reading).

Minor Type ^{1/4}



Product Number	Torque Range		Weight each	Order Code
	cNm	ozf.in		
S50H	10-50	14-70	190g	-8050K
S100H	20-100	28-140	190g	-8100K

Standard Type

Can be used with 1/4" drive. Sliding 'T' bar supplied.

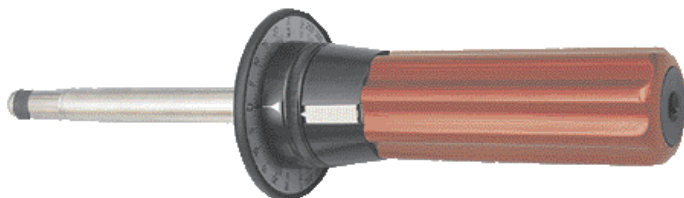

Product Number	Torque Range		Weight each	Order Code
	cNm	lbf.in		
S250H	50-250	4-20	465g	-8250K
S500H	100-500	8-40	465g	-8500K

Quick-Set Torque Drivers

^{1/4} Micrometer style adjustment allows easy accurate setting. Slipping action at pre-set torque eliminates overtightening. The adjustment ring automatically disengages when the tool is in use to prevent accidental adjustment. Stainless steel shafts. Anodised aluminium handles. Suitable for electrical, electronics and instrument assembly works. Manufactured to **ISO 6789 : 2003**. (Accuracy ±6% of reading).

Minor Type



Product Number	Torque Range		Weight each	Order Code
	cNm	ozf.in		
QS12MH	20-120	-	165g	-5010K
QS12IH	-	20-120	165g	-5020K
QS9FH	490	-	335g	-5520K
QS80FH	-	1.875-5	335g	-5540K

Standard Type

^{1/4} Can be used with 1/4" hexagon drive. Sliding 'T' bar supplied.



Product Number	Torque Range		Weight each	Order Code
	Nm	lbf.in		
QS6MH	1-6	-	335g	-5600K
QS50IH	-	5-50	335g	-5500K

Torque Limiting Screwdrivers

L" A/F female hexagon socket which will accept screwdriver bits. Can be converted to a male end by using the appropriate adaptor. Can be pre-set to any torque value within range by using a Torque Calibration Analyser. Can be fitted with 'impact-free resetting' option. Manufactured to **ISO 6789 : 2003**. (Repeatability at ±6% of set torque).

LS135H

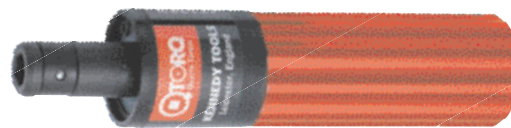

LS406H

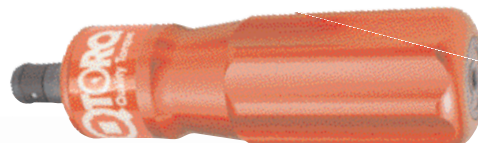

LS1360FH

Product Number	Torque Range		Weight each	Order Code
	cNm	lbf.in		
LS135H	2-135	12	200g	-5700K
LS406H	6-406	36	300g	-5800K
LS1360FH	2.5-13.6	22	325g	-5680K

TT Torque Screwdrivers

Supplied with a 1/4" hexagon bit holder designed using a 4mm hexagon stem. Easy torque adjustment without the need of additional special tools. All tools feature a lock to prevent accidental adjustment of the set torque. Accuracy exceeds the requirements of **ISO6789**. Traceable calibration certificate for the clockwise direction supplied with all adjustable tools (not 'P'Types). Comfortable and durable handle.



Product Number	Torque Range	Length (mm)	Order Code
13850	0.3-1.5	155	-3350A
13851	0.6-3	155	-3350C
13852	1.2-6	155	-3350E
13853	2.5-13	155	-3350G
13854	5-26	155	-3350J
13855	10-53	155	-3350L
13856	0.3-1.5/2.5-13	155	-3350N
13857	0.6-3/2.5-13	155	-3350Q
13858	1.2-6/10-53	155	-3350S



Preset Torque Screwdriver

Eliminates under and over tightening due to the slipping technology to ensure accurate process control. Dual formed ergonomic hand grip and smooth tool reset action.

The ESD models of Preset Torque Screwdrivers are ideal for safe electronic component assembly as these are EPA compliant.

Product Number	Torque Range (Nm)	Length (mm)	Order Code KEN-555
PM150	0.2-1.5	138	-8600K
PM450	0.5-1.5	138	-8620K
P25FH	0.05-0.25	132	-8640K
E25FH (ESD)	0.05-0.25	132	-8660K
P150FH	0.2-1.5	132	-8680K
E150FH (ESD)	0.2-1.5	132	-8700K
P450FH	0.5-4.5	140	-8720K
E450FH (ESD)	0.5-4.5	140	-8740K
P1350FH	2.5-13.5	140	-8760K
E1350FH (ESD)	2.5-13.5	140	-8780K

Micro Torque Screwdriver

LS0022 FH

Clear audible click when reaching the set torque and smooth reset action.

Drive type: hexagon

Torque range: 0.002 - 13.6Nm

Repeatable accuracy: +/-1%



Product Number	Torque range	Order Code KEN-555
LS0022FH	0.002Nm - 13.6Nm	-5660K

Adjustable Torque Screwdriver

These Calibrated Torque Screwdrivers are fast and accurate to set. Wide torque range and long service life is provided through the durable design utilising hard wearing materials stainless steel and aluminium. This tool is EPA compliant for use in Electrostatically Sensitive Areas.



Product Number	Torque Range (Nm)	Length (mm)	Order Code KEN-555
QS120FH	0.2-1.2	183	-5920K
QS600FH	1-6	196	-5940K
QS900FH	4-9	196	-5960K
QS40FH	0.08-0.4	159	-5980K

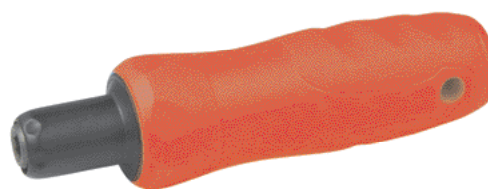

-8600K



-8640K



-8660K

Torque Wrenches

1/4" Hex. Drive Adjustable Reversible Precision

Non length-dependent wrench, remaining accurate regardless of hand position. Accuracy of ±3% exceeds normal torque wrench standards. With coloured end seals. With calibration certificate fully traceable and suitable for ISO9000 assessment purposes.

All Norbar torque wrenches are designed and manufactured to exceed the following national and international standards: **BS6703: 1988, ISO 6789: 1992 & U.S.A.GGG-W-00686-C (GSA-FSS).**



Product Number	Torque Range	Length (mm)	Weight each	Order Code NBD-555
13001	1-5 Nm	170	120g	-1601A
13002	10-50lb.in	170	120g	-1602B

wiha Engineer's Torque Screwdriver Set

13 PIECES

TorqueVario-S torque screwdriver set 13 piece compact set, essential for accurate and effective work. Ergonomic Soft Finish grip for comfort during repetitive tasks, light, compact, modern design. Calibrated, certified and traceable to EN 6789 with an accuracy of +/-6%. Metal box with cut-foam insert contains TorqueVario-S torque screwdriver, setter, bit holder and 10 of L" bits. Also compatible with Wiha's one piece torque blades for unrivalled access in tight spaces

Contents: handle 1.0 - 5.0Nm, 1/4" hex dr. universal bit holder, torque setter screwdriver.

Screwdriver bits: Phillips: PH1, PH2, Pozidriv: PZ1, PZ2, Torx: T10, T15, T20, T25, Hex 3, 4mm.

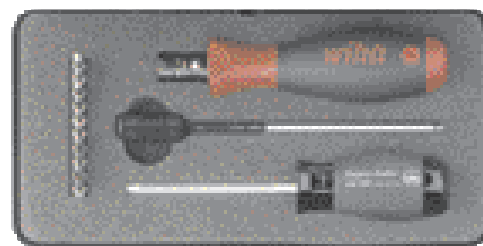

Product Number	Number of Pieces	Order Code WIH-555
26893	13	-6893B

Order online at cromwell.co.uk or call

North 0800 028 3602 | Central 0800 028 3191 | South 0800 028 3189



Production Slipper Torque Wrenches

Wrench 'slips' when predetermined torque setting is reached, completely eliminating overtightening. Fitted with Mechanical Torque Adjustment Locking Device. Accurate repeatability guarantees equal tightness every time. Incorporates a specially designed multi-lobed cam which automatically resets the wrench after a small movement of the handle, allowing quick progress to the next operation. Incorporates a fully supported ratchet giving smooth, positive torque control, even in confined spaces. Lightweight for less operator fatigue. Manufactured to **ISO 6789 : 2003**.
(Repeatability at ±4% of reading).

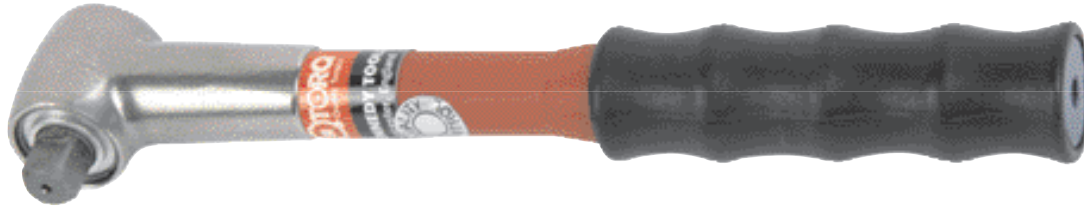

Product Number	Torque Range		Length (mm)	Ratchet Size	Order Code KEN-555
	Nm	lbf/ft			
MPW125	40-125	30-90	460	1/2"	-4000K
SPW25	3-25	2-18	216	3/8"	-4050K
SPW55	15-55	10-40	325	3/8"	-4070K
TPW25	3-25	2-18	216	1/4"	-4100K

Mechanical Torque Adjustment Lock

- Easy-to-use locking device for the torque adjusting screws.
- Positive, mechanical locking system.
- Does not rely on friction to arrest movement.
- Operated using a single adjusting key.

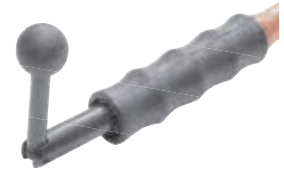

Slipping Wrench

These TSC Adjustable Wrenches improve control of the fastening process by reducing the risk of both under and over tightening; this is achieved by the unique slipping mechanism. Its slim line and compact design maximizes productivity in restricted spaces as well as being long lasting and durable. EPA Compliant for use in Electrostatically Sensitive Applications.

ISO 6789 : 2003.

(Repeatability at ±6% of reading).

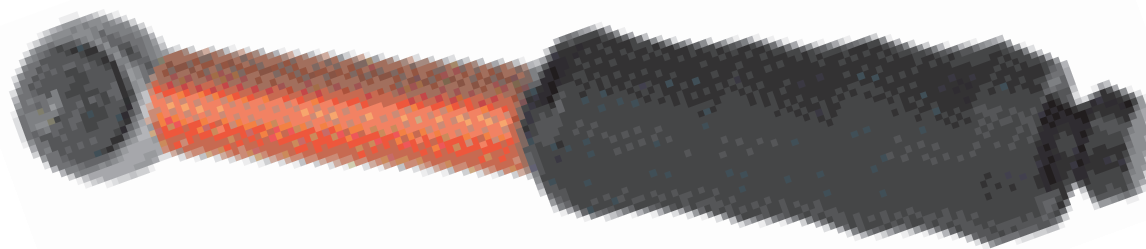

Product Number	Torque Range		Length (mm)	Order Code KEN-555
	lbf/ft	Nm		
TCW45	10 to 45	195	195	-7150K
TCW90	20 to 90	195	195	-7200K

Calibrated Slipper Wrenches

Featuring micrometer style, fine adjustment with positive locking system and clearly audible click when reaching the set torque.

Aircraft specification stainless steel heads

Aluminium handles

Micrometer type sleeve allows torque values to be accurately set

Automatic resetting with audible click when the wrench slips

Drive type: square

Drive size: 1/4"

Repeatable accuracy: +/- 6%

Length: 195mm



Drive Size	Torque Range		Weight each	Order Code KEN-555
	Nm	Increment		
1/4"	1-5	0.05Nm	235g	-7052K
1/4"	2-10	0.1Nm	235g	-7102K

1050

Visit cromwell.co.uk for our latest price or your online trading account

Order before **5PM** for **Next Day Delivery** on stocked items

All prices exclude VAT © 2021

SENATOR Square Drive Torque Wrench

Reversible ratchet head. 'Click + Snap' action indicates when the pre-set torque level has been reached. Engraved kgf.m and Nm scale on barrel. Micrometer type sleeve allows preset torque values to be accurately set. Manufactured to ISO 6789-2:2017.

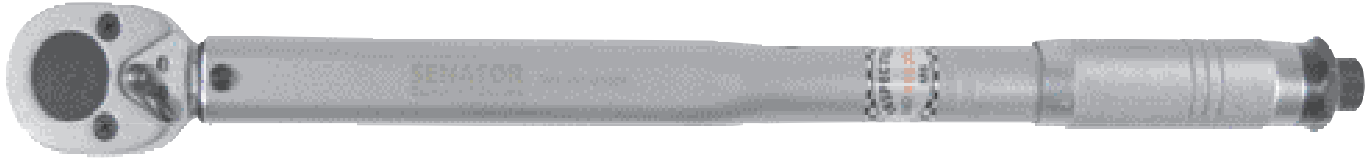

Overall Length	Sq. Drive	Torque Range		Order Code
		Nm	kgf.m	
280mm*	1/4"	5-25	0.5-2.5	-0300K
365mm	3/8"	19-110	1.9-11.2	-0400K
440mm	1/2"	42-210	4.2-21.4	-0500K

1/4 3/8 1/2

TRI TORQ Adjustable Torque Wrench

Manufactured from high quality satin finish steel with a polished steel head. Supplied with a fully traceable calibration certificate and storage case. The desired torque value can be set, and is displayed in windows on the handle. Manufactured to ISO 6789-2:2017.



Supplied in Robust Storage Case



1/4 3/8 1/2

Model Number	Sq. Drive	Torque Range		Weight each	Order Code
		Nm	lbf.ft		
FXL5	1/4"	1-5	0.7-3	0.40kg	-5740K
FXL32	1/4"	6-30	4-22	0.40kg	-5760K
FXL33	3/8"	6-30	4-22	0.40kg	-5850K
FXL63	3/8"	12-60	7-44	1.30kg	-5870K
FXL100	3/8"	20-100	15-75	1.38kg	-5900K
FXL200	1/2"	40-200	30-150	2.36kg	-6900K
FXL320	1/2"	60-320	45-225	2.57kg	-6920K

With Factory Tested Calibration Certificate

Ratchet Repair Kits

To Suit	Order Code
FXL100	-5900K
FXL200/FXL320	-6900K

TORO Preset Torque Slipping Wrench

Ensure accurate process control is guaranteed by eliminating under and over tightening. EPA Compliant for use in Electrostatically Sensitive Applications. ISO 6789 : 2003. (Repeatability at ±6% of reading).

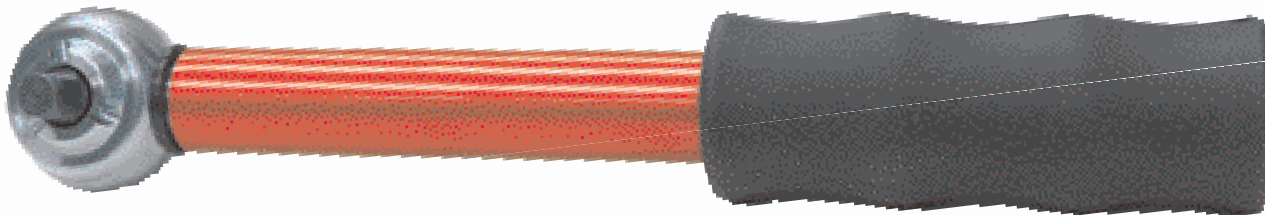

Product Number	Torque Range (Nm)	Length (mm)	Order Code
SP5	1 to 5	185	-7250K
SP10	2 to 10	185	-7300K

Order online at cromwell.co.uk or call North **0800 028 3602** | Central **0800 028 3191** | South **0800 028 3189**



Adjustable Torque Wrenches

High quality chrome-plated, polished steel head and retractable torque setting lever. 'Click and Snap' action indicates when the pre-set torque level has been reached. Four easy read scales Nm, kgf.m, lbf.in x10, lbf.ft. Push through square drive connector to instantly reverse action. Knurled grip plastic handle. Complete with factory tested calibration certificate, operating instructions and torque conversion chart. Supplied in a cardboard case. Manufactured to **ISO 6789 : 2003 (BS EN 26789 : 2003)**. Accuracy = $\pm 4\%$.

With Factory Tested Calibration Certificate



Model Number	Square Drive	Torque Range		Length (mm)	Order Code KEN-557
		Nm	lbf.ft		
MTW011	3/8"	2.5 - 11	2 - 8	300	-3500K
MTW033	3/8"	5.0 - 33	4 - 24	410	-3520K
MTW068	3/8"	12.0 - 68	10 - 50	480	-3540K
MTW135	1/2"	25 - 135	20 - 100	560	-3560K
MTW225	1/2"	50 - 225	40 - 160	610	-3580K
MTW330	1/2"	70 - 330	50 - 250	780	-3600K
MTW810	3/4"	200 - 800	145 - 600	940	-3610K

Replacement Squares for Torque Wrenches

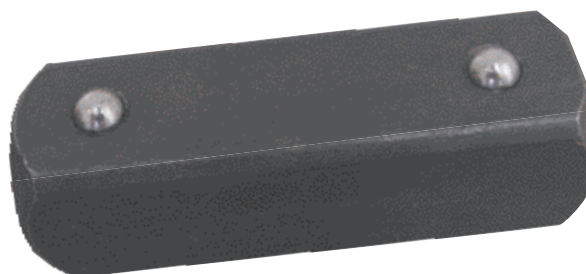

Square Drive	To Suit	Order Code KEN-567
3/8"	-3500K	-1500K
3/8"	-3520K	-1510K
3/8"	-3540K	-1510K
1/2"	-3580K	-1520K
1/2"	-3600K	-1520K
3/4"	-3610K	-1530K

Torque Conversion Factors

To From	International System S.I.			Inch			Metric		
	mNm	cNm	Nm	Ozf.in	lbf.in	lbf.ft	gf.cm	kgf.cm	kgf.m
mNm	1	0.1	0.001	0.142	0.009	0.0007	10.2	0.01	0.0001
cNm	10	1	0.01	1.416	0.088	0.007	102	0.102	0.001
Nm	1000	100	1	141.6	8.851	0.738	10197	10.20	0.102
Ozf.in	7.062	0.706	0.007	1	0.0625	0.005	72	0.072	0.0007
lbf.in	113	11.3	0.113	16	1	0.083	1152.1	1.152	0.0115
lbf.ft	1356	135.6	1.356	192	12	1	13.826	13.83	0.138
gf.cm	0.098	0.01	0.0001	0.014	0.0009	0.00007	1	0.001	0.00001
kgf.cm	98.07	9.807	0.098	13.89	0.868	0.072	1000	1	0.01
kgf.m	9807	980.7	9.807	1389	86.8	7.233	100000	100	1

EXAMPLE: To convert 10 lbf.ft to Nm, read across (units to be converted from) and down (units to be converted to) as shown above to obtain

Torque Conversion Factor.

Number of Units to be Converted x Conversion Factor = Total Converted Units
i.e: 10 lbf.ft x 1.356 = 13.56 Nm

Note: The unit Kilogramme Force (kgf.m) is also known as Kilopond (kp.m), 1kgf.m=1kp.m



Angular Torque Gauge

The gauge has an easy to read 360° scale in 2°, 10° and 30° increments and has an Indicator etched into the clear plastic. An adjustable arm to keep the angled scale stationary, with a long and short side for flexibility in positioning against components.



Product Number	Capacity Nm	Order Code KEN-557
TGA360	0 - 360	-0150K

1052

1/2" Square Drive Torque & Angled Adaptors

E.506

Accuracy: torque $\pm 3\%$ between 20% and 100% wrench capacity, angle: $\pm 2^\circ$. Measuring mode: peak or track follower. Cycle counter. Locking keypad (the operator has access only to program choices and memorise results). Measuring unit: N.m, ft.lb, In.lb, kg.cm, deg. Presetting possible of nine torque and/or angle values.

Memory 50 values.

Length: 80mm.

1/2" Square Drive



Product Number	Capacity Nm	Order Code FAC-582
E.506-135S	135	-5310C

Visit cromwell.co.uk for our latest price or your online trading account

Order before **5PM** for **Next Day Delivery** on stocked items

All prices exclude VAT© 2021